



US009589554B2

(12) **United States Patent**  
**Eventoff**

(10) **Patent No.:** **US 9,589,554 B2**  
(45) **Date of Patent:** **Mar. 7, 2017**

(54) **ELECTRONIC MUSICAL INSTRUMENTS**

*3/00* (2013.01); *G10H 3/181* (2013.01); *G10H 3/182* (2013.01); *G10H 2220/301* (2013.01); *G10H 2220/361* (2013.01); *G10H 2220/561* (2013.01)

(71) Applicant: **Sensitronics, LLC**, Bow, WA (US)

(72) Inventor: **Franklin N. Eventoff**, Bow, WA (US)

(73) Assignee: **Sensitronics, LLC**, Bow, WA (US)

(\*) Notice: Subject to any disclaimer, the term of this patent is extended or adjusted under 35 U.S.C. 154(b) by 0 days.

(58) **Field of Classification Search**

CPC ..... *G10H 2220/361*; *G10H 2230/221*; *G10H 1/0558*; *G10H 2250/461*; *G10H 3/185*; *G10H 3/182*; *G10H 3/181*; *G10H 1/342*; *G10H 2220/301*; *G10H 2220/561*  
USPC ..... 84/723, 734, 744  
See application file for complete search history.

(21) Appl. No.: **15/176,001**

(56) **References Cited**

(22) Filed: **Jun. 7, 2016**

U.S. PATENT DOCUMENTS

(65) **Prior Publication Data**

US 2016/0284330 A1 Sep. 29, 2016

4,268,815 A *	5/1981	Eventoff	.....	H01H 1/029
				338/114
4,489,302 A *	12/1984	Eventoff	.....	B60C 23/0408
				338/100
4,810,992 A *	3/1989	Eventoff	.....	G06F 3/045
				338/114
4,858,509 A *	8/1989	Marshall	.....	G10H 1/0066
				84/646
5,033,351 A *	7/1991	Nomura	.....	G10H 1/342
				84/646
5,153,364 A *	10/1992	Uchiyama	.....	G10H 1/342
				200/5 A
5,245,130 A *	9/1993	Wheaton	.....	G10H 1/0066
				84/377
6,005,181 A *	12/1999	Adams	.....	G10H 1/0558
				84/734

**Related U.S. Application Data**

(63) Continuation of application No. 14/949,652, filed on Nov. 23, 2015, now Pat. No. 9,361,870, which is a continuation of application No. 14/667,426, filed on Mar. 24, 2015, now Pat. No. 9,214,146, which is a continuation of application No. 14/216,803, filed on Mar. 17, 2014, now Pat. No. 6,987,577.

(60) Provisional application No. 61/794,361, filed on Mar. 15, 2013.

(Continued)

(51) **Int. Cl.**

*G10H 3/14* (2006.01)  
*G10H 3/18* (2006.01)  
*G10H 1/055* (2006.01)  
*G10H 1/34* (2006.01)  
*G10H 3/00* (2006.01)  
*G01L 1/20* (2006.01)

Primary Examiner — Jeffrey Donels

(74) *Attorney, Agent, or Firm* — K. David Crockett, Esq.; Paul J. Backofen, Esq.; Crockett & Crockett, PC

(52) **U.S. Cl.**

CPC ..... *G10H 3/185* (2013.01); *G01L 1/20* (2013.01); *G10H 1/0558* (2013.01); *G10H 1/34* (2013.01); *G10H 1/342* (2013.01); *G10H*

(57) **ABSTRACT**

Electronic musical instruments as disclosed, include sensors to digitize and alter the sound using FSR sensors in the mouthpieces and other elements of the instrument to mimic the variations available in analog instruments.

**9 Claims, 28 Drawing Sheets**

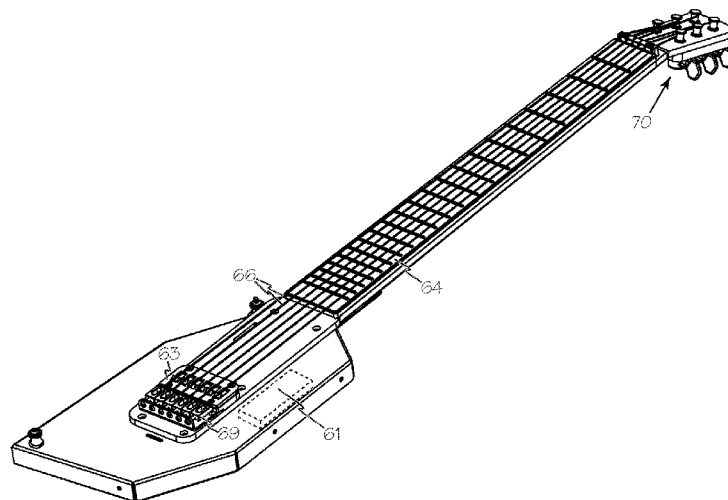

(56)

**References Cited**

U.S. PATENT DOCUMENTS

6,018,118 A \* 1/2000 Smith ..... G10H 1/0066  
84/600  
7,741,555 B2 \* 6/2010 Onozawa ..... G10H 1/34  
84/337  
7,829,780 B2 \* 11/2010 Onozawa ..... G10D 7/00  
84/385 R  
8,607,651 B2 \* 12/2013 Eventoff ..... G06F 3/044  
73/862.041  
2011/0011248 A1 \* 1/2011 Elion ..... G10H 1/0066  
84/646  
2014/0090547 A1 \* 4/2014 Udell, III ..... G10H 1/0091  
84/626  
2015/0262559 A1 \* 9/2015 Beck ..... G10H 1/0016  
84/645

\* cited by examiner

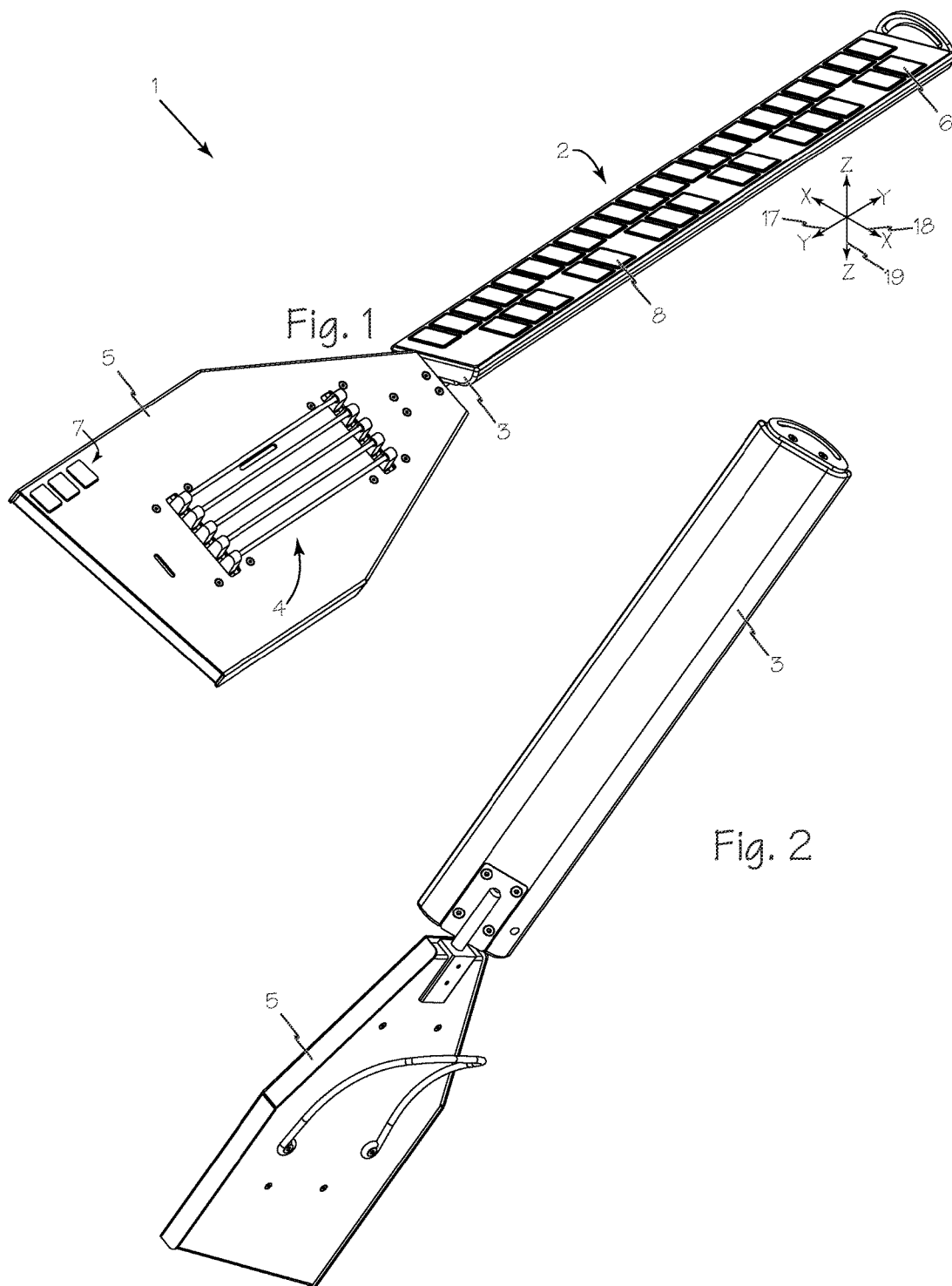

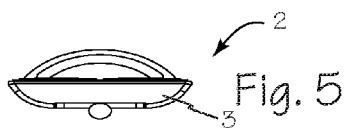
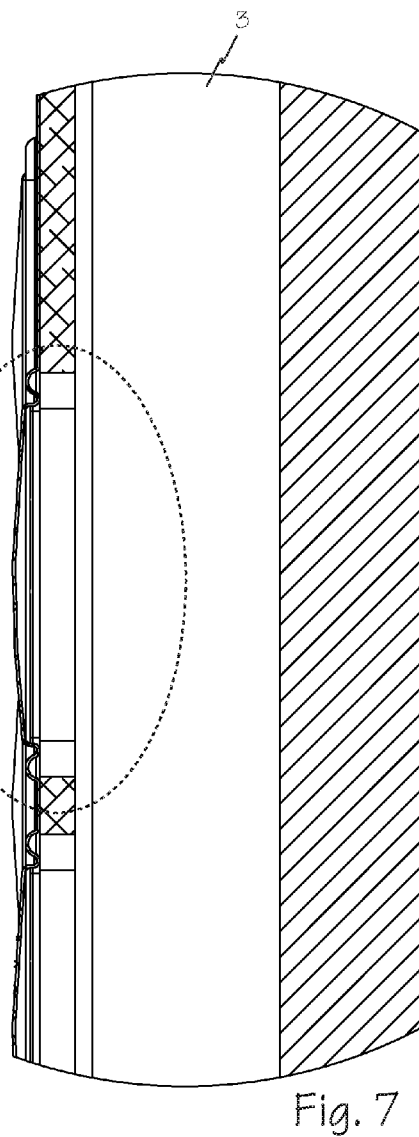
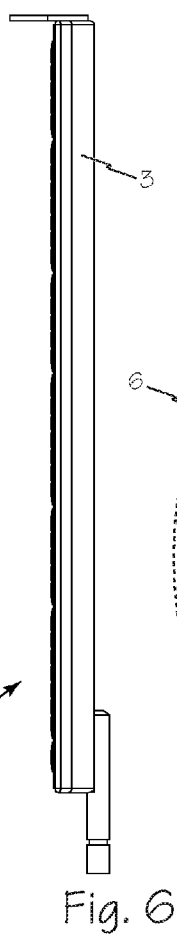
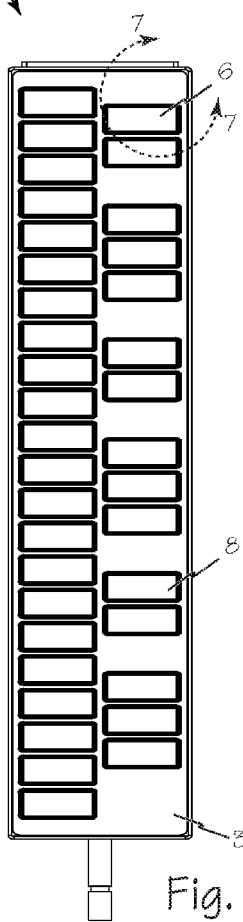
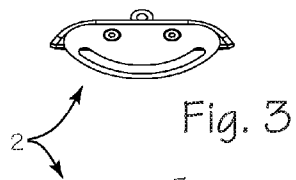

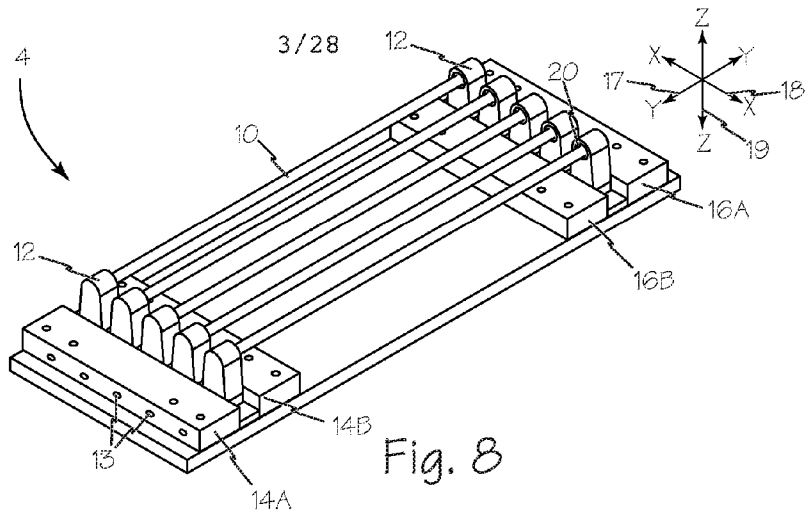

Fig. 8

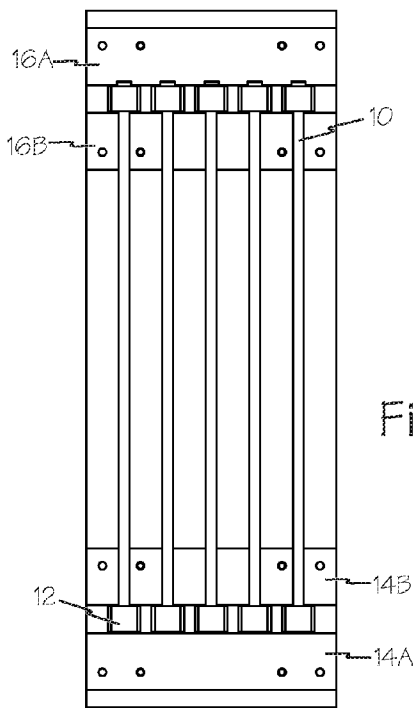

Fig. 9

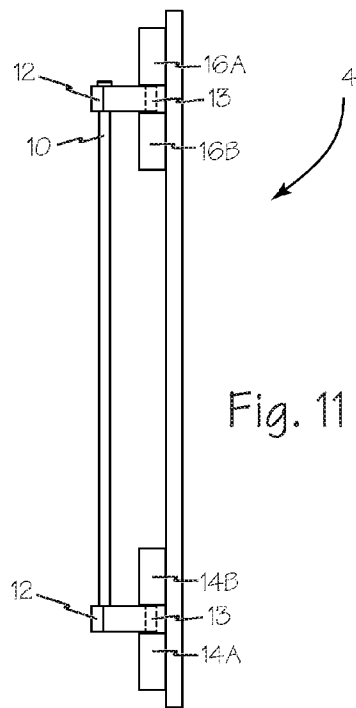

Fig. 11

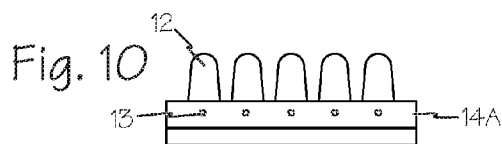
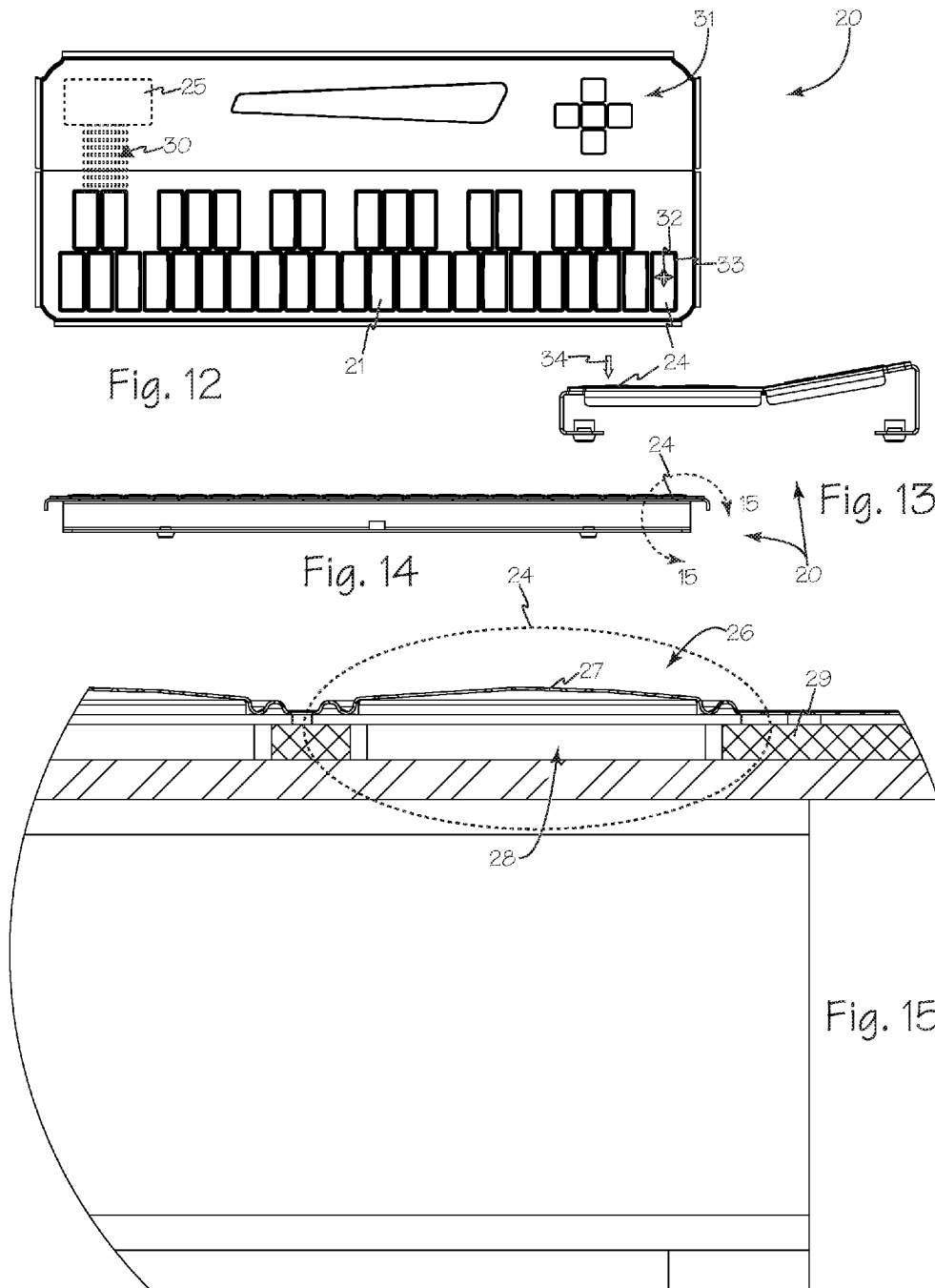

Fig. 10



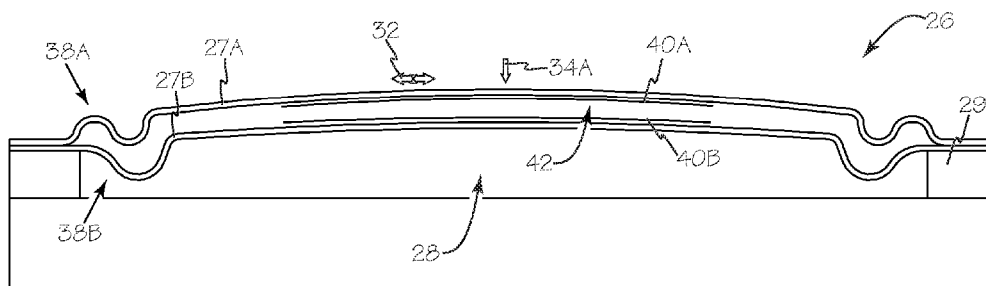

Fig. 16

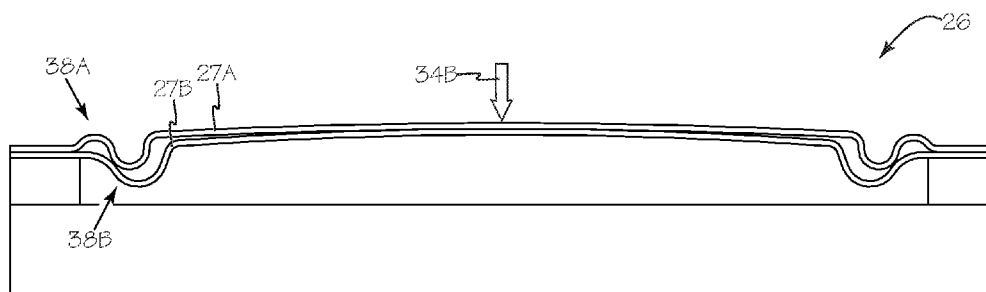

Fig. 17

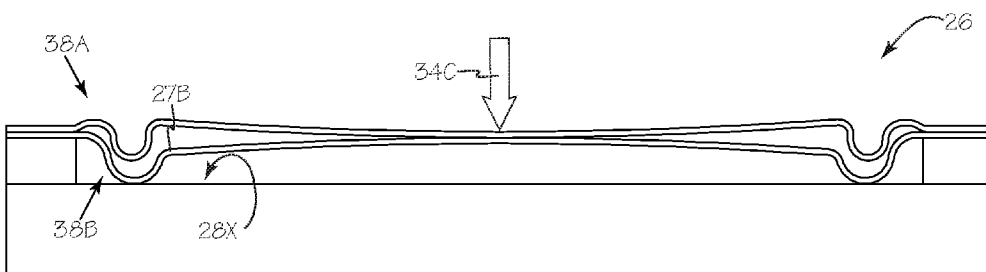

Fig. 18

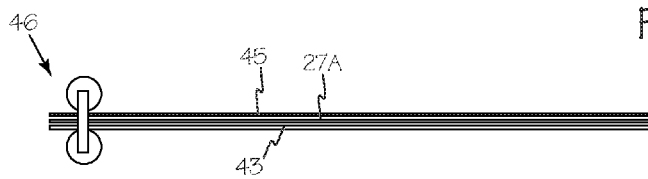

Fig. 18X

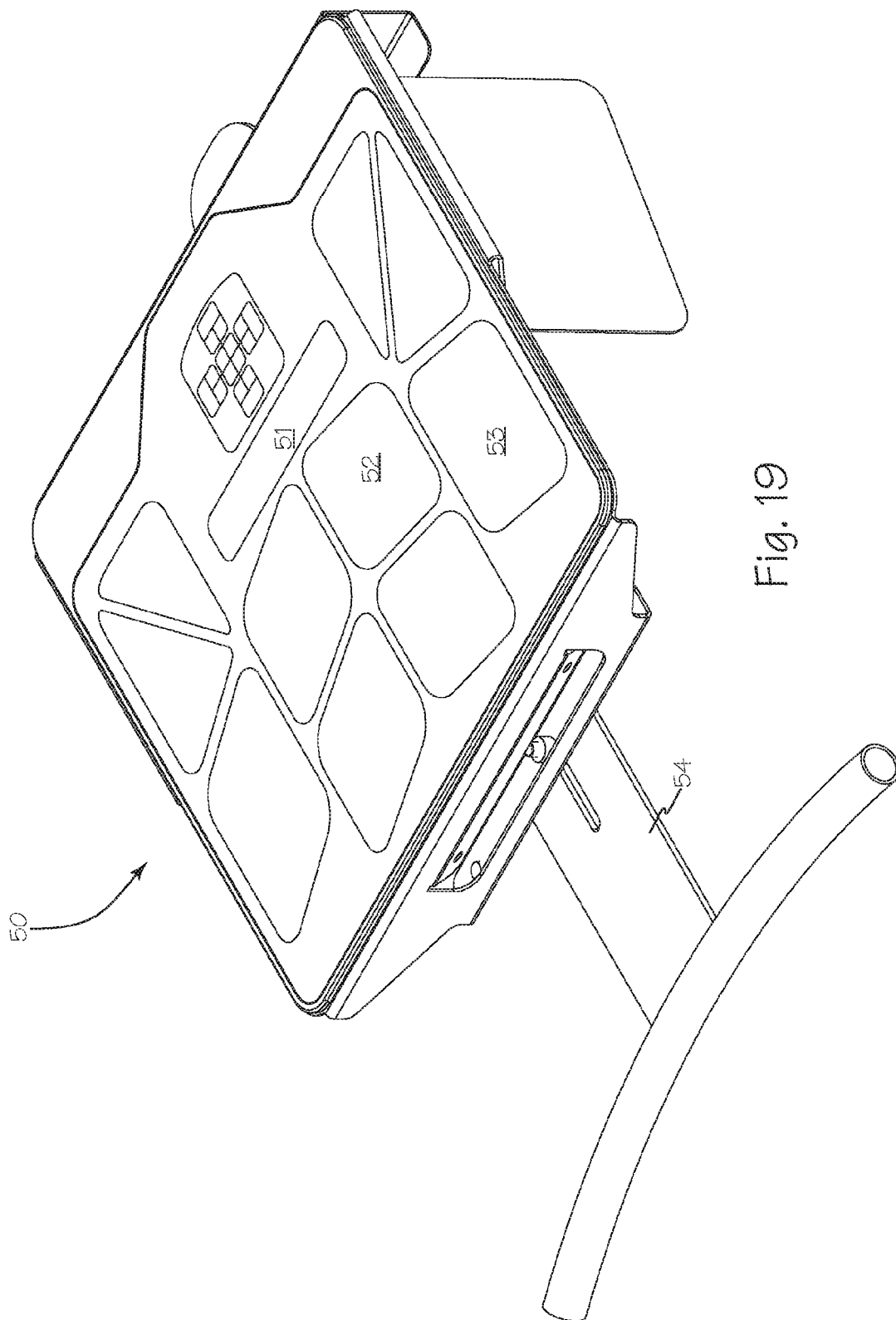

Fig. 19



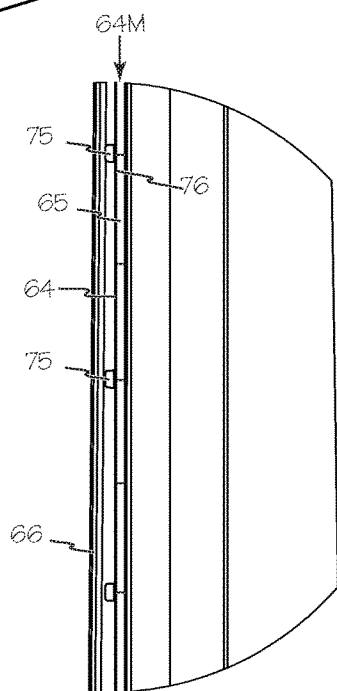
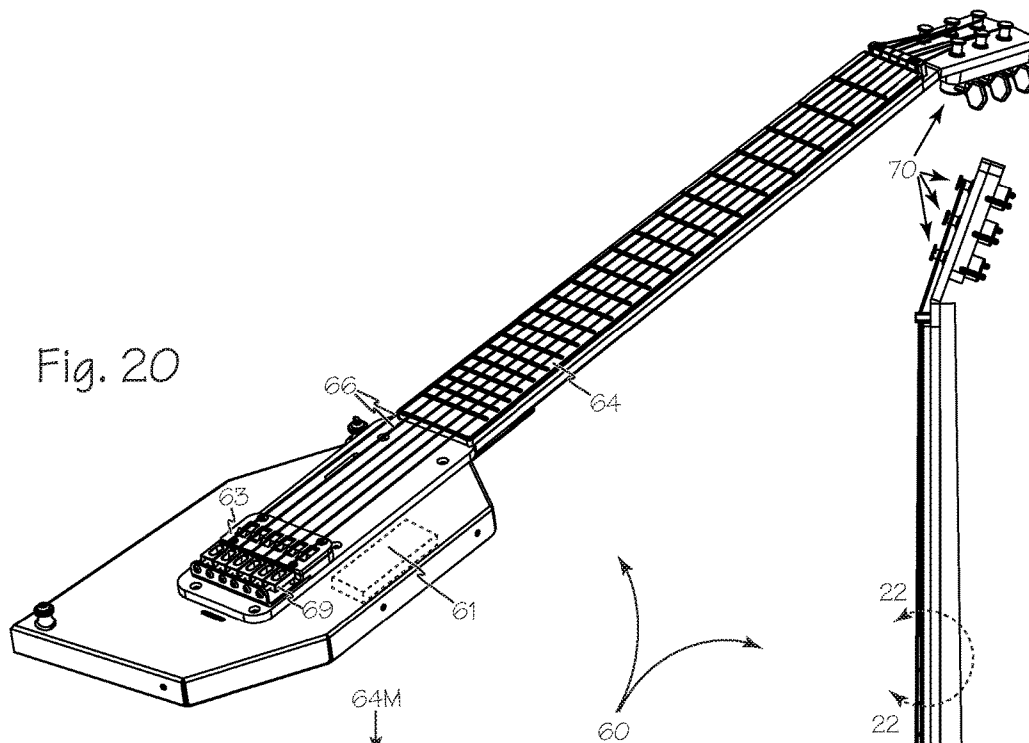

Fig. 22

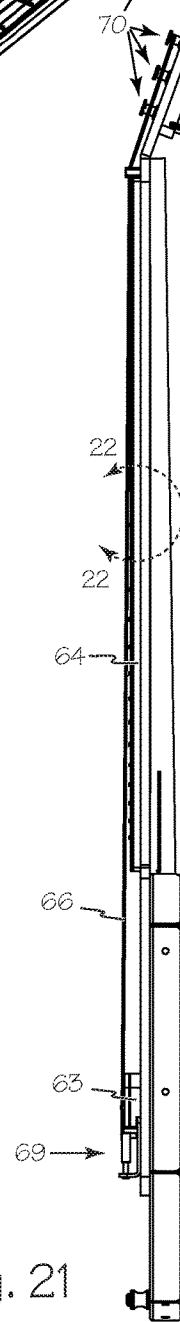
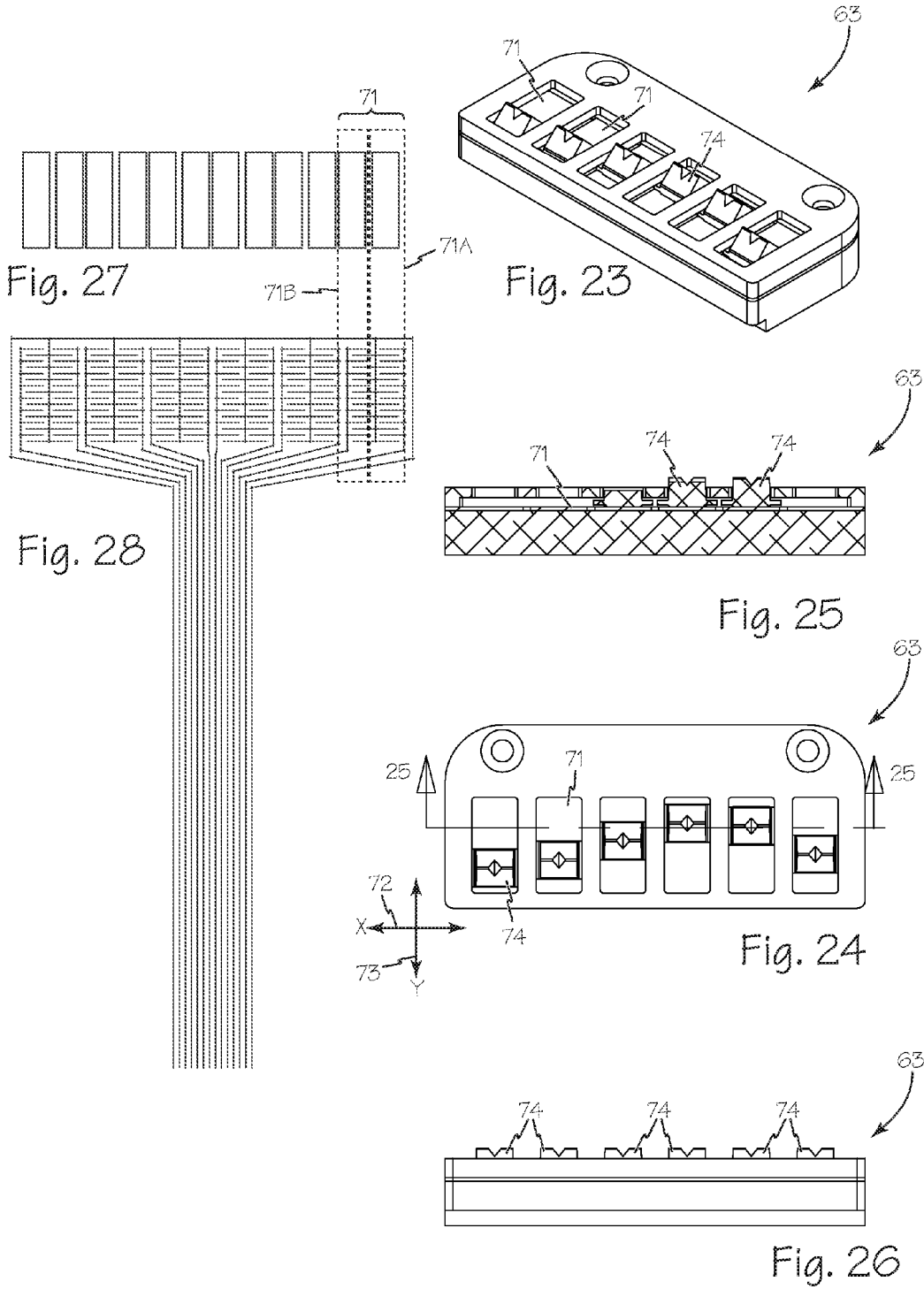
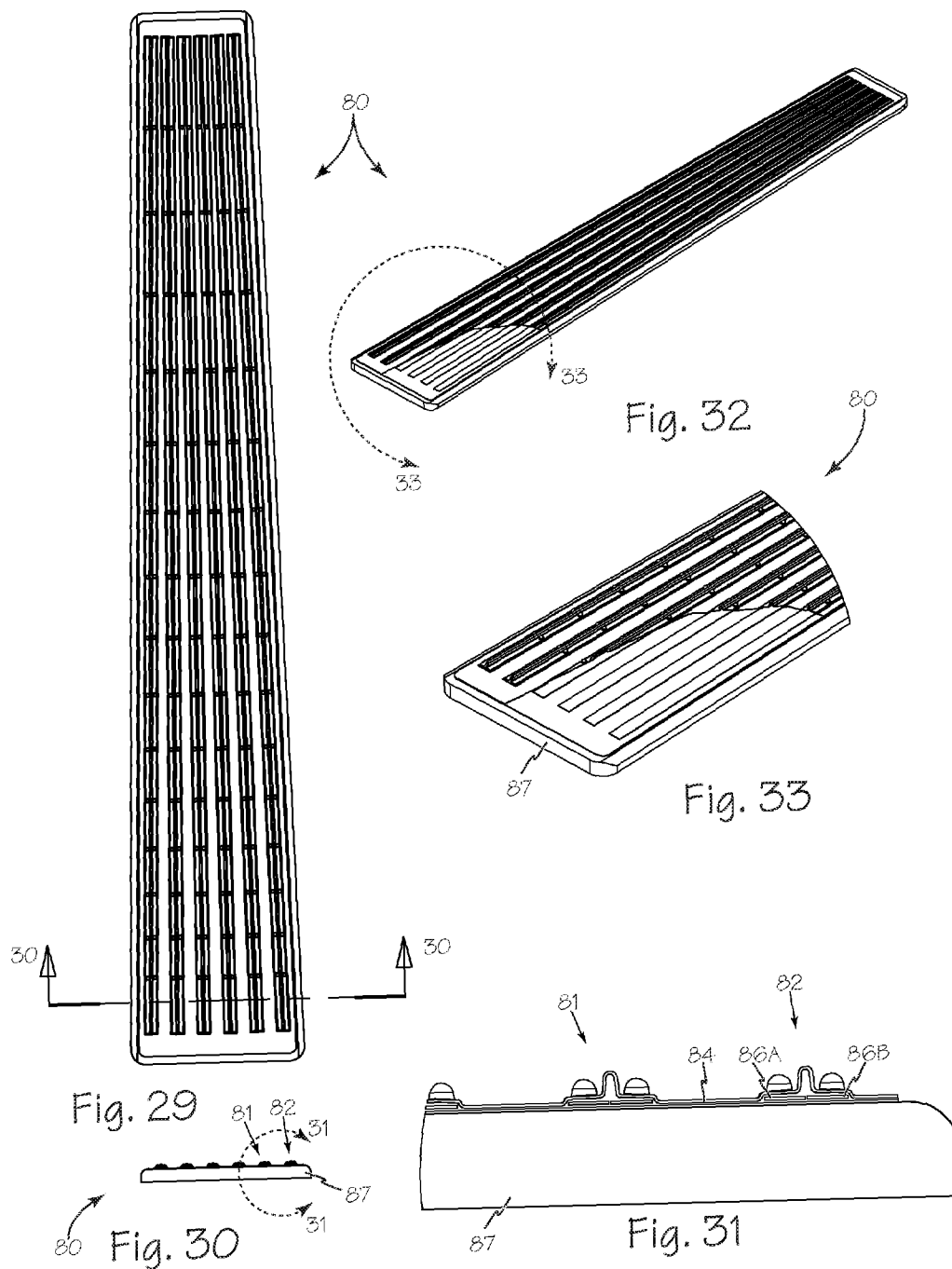

Fig. 21





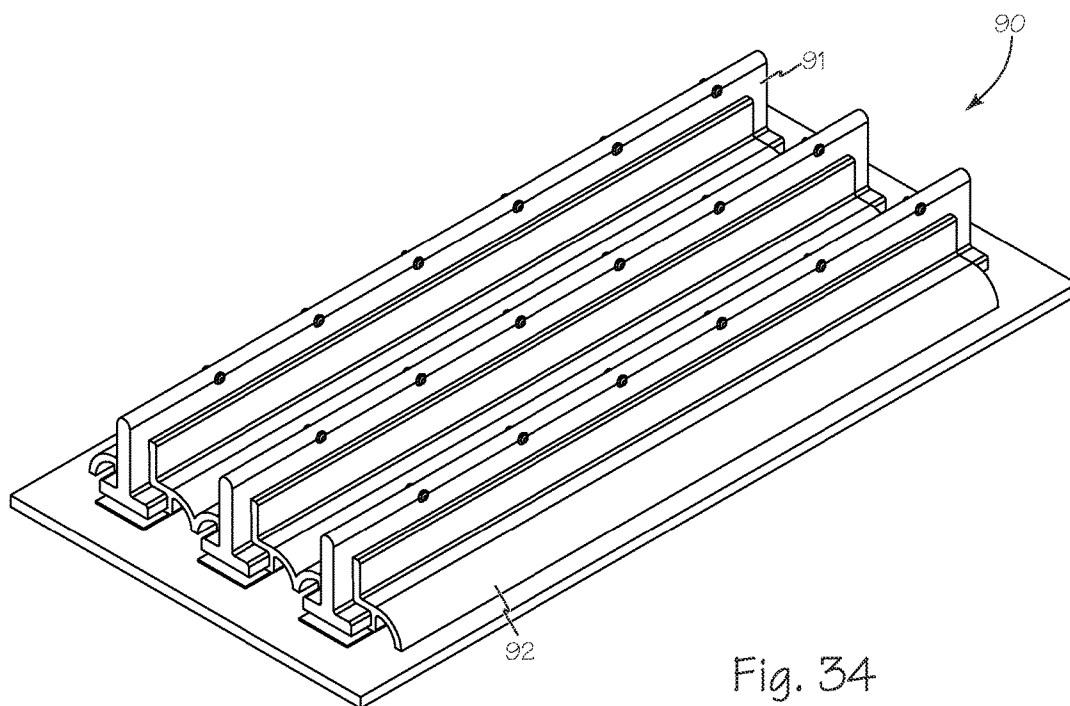

Fig. 34

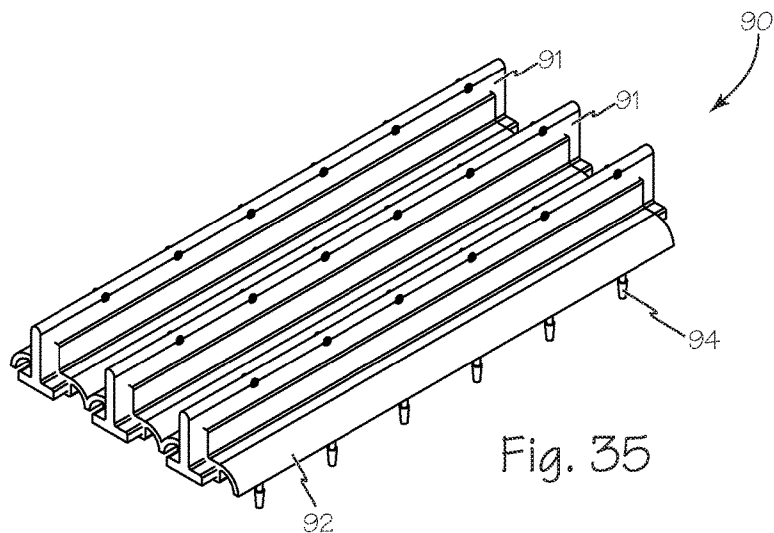

Fig. 35

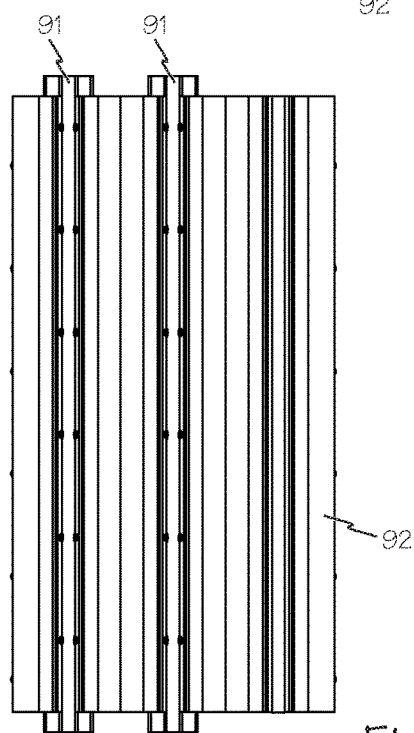

Fig. 36

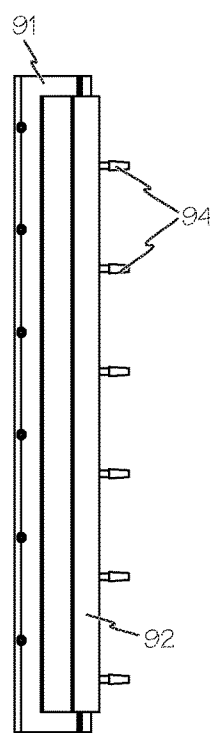

Fig. 38

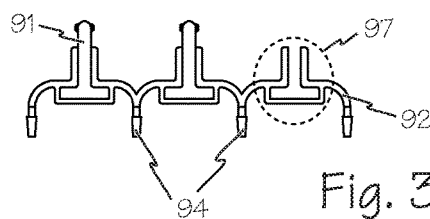

Fig. 37

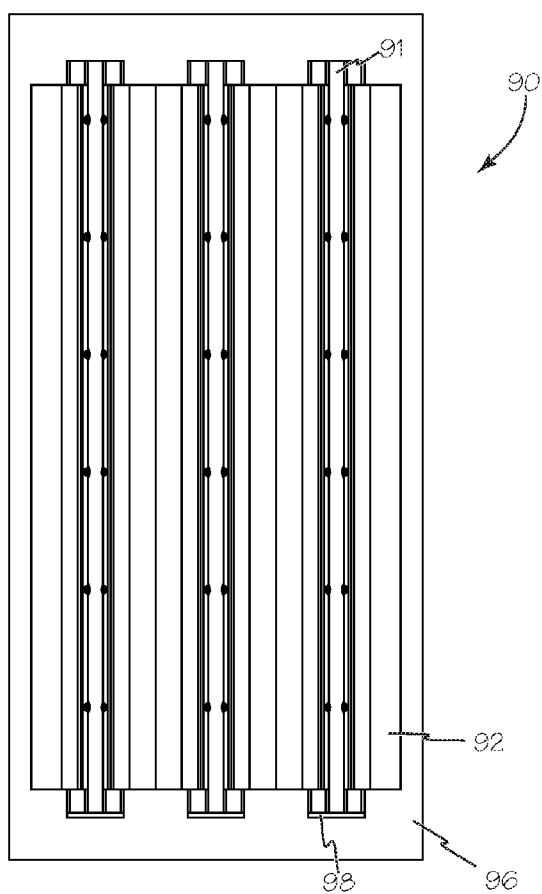

Fig. 39

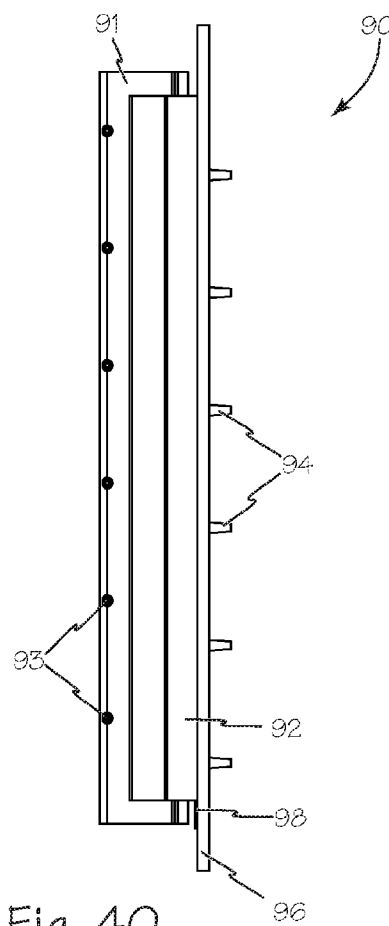

Fig. 40

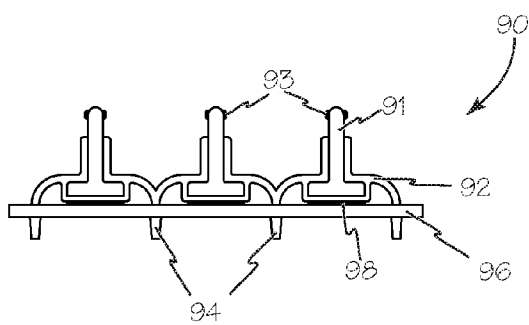

Fig. 41

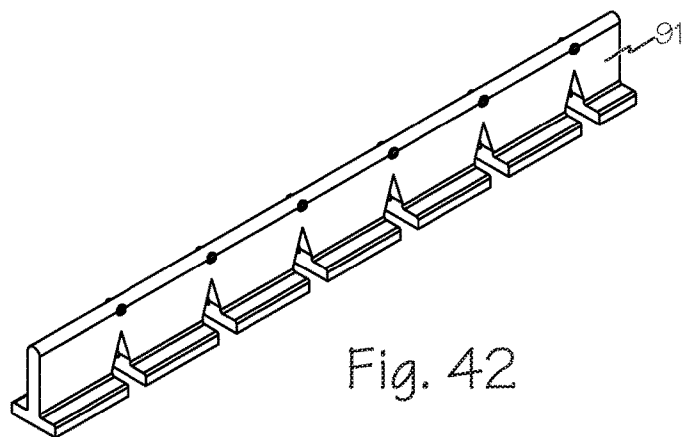

Fig. 42

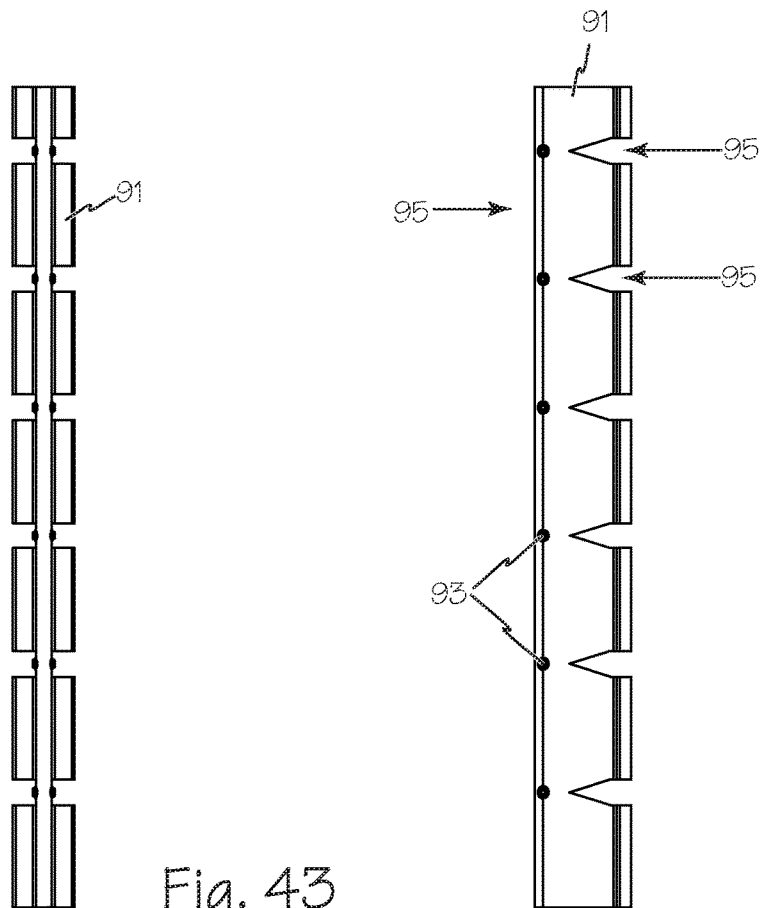

Fig. 43

Fig. 44

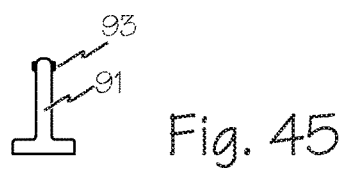

Fig. 45

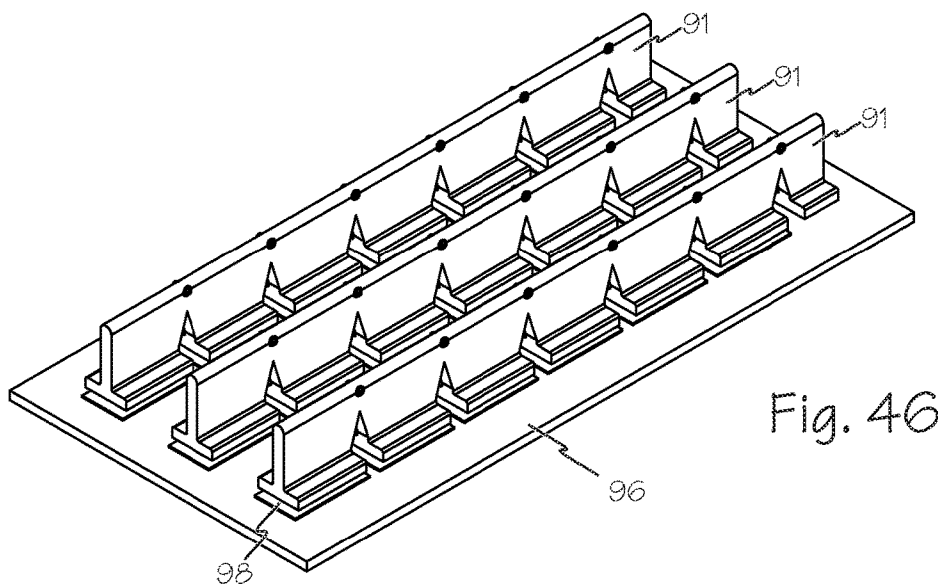

Fig. 46

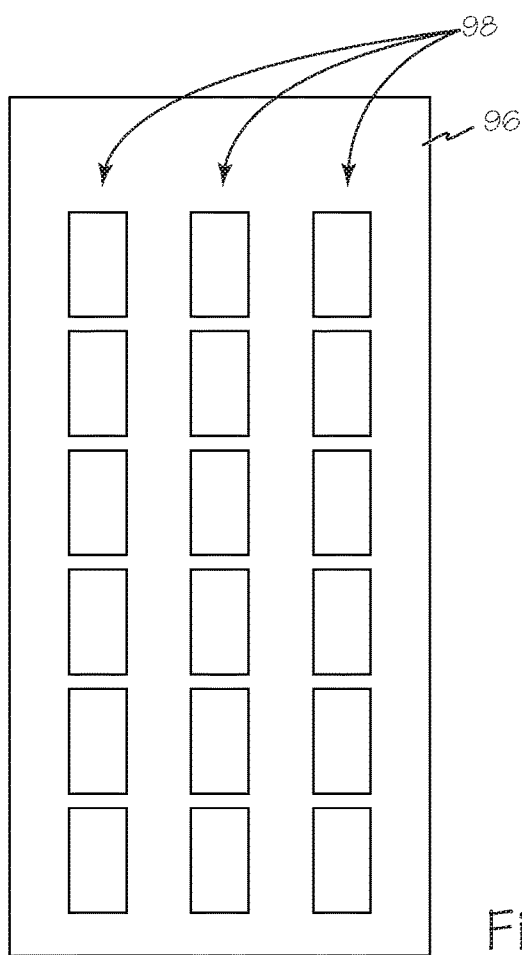

Fig. 47

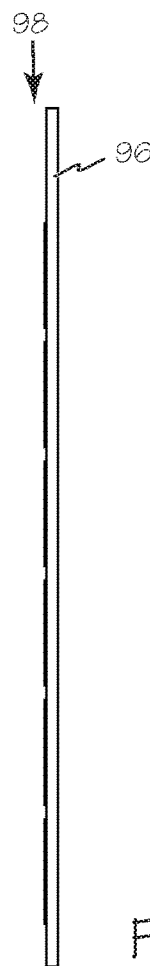

Fig. 48



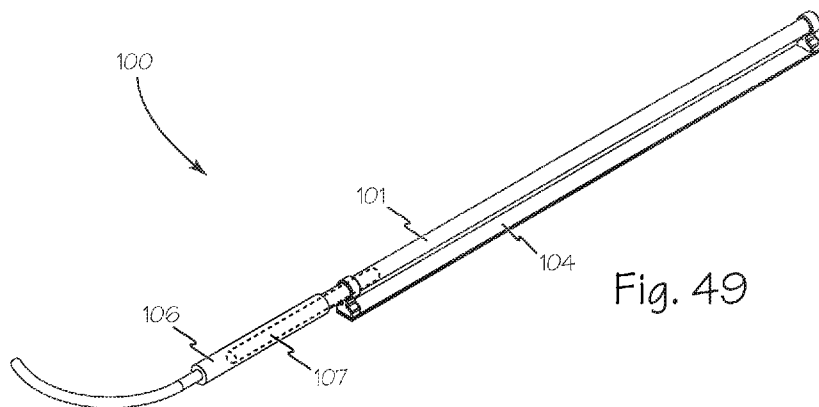

Fig. 49

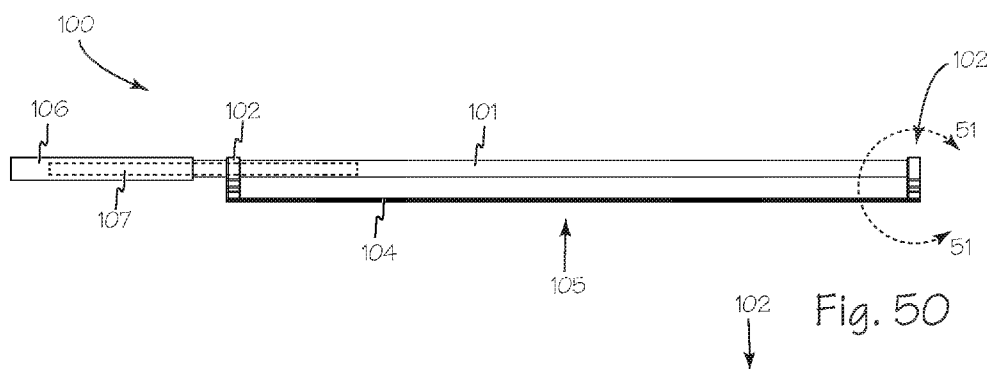

Fig. 50

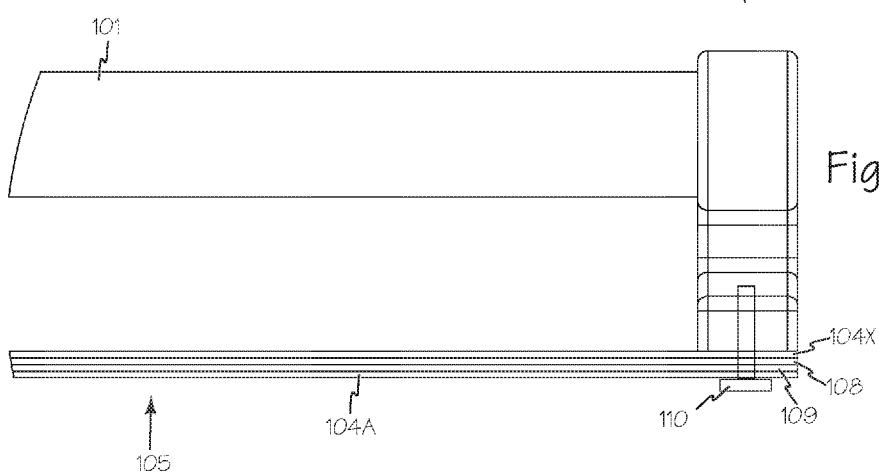

Fig. 51

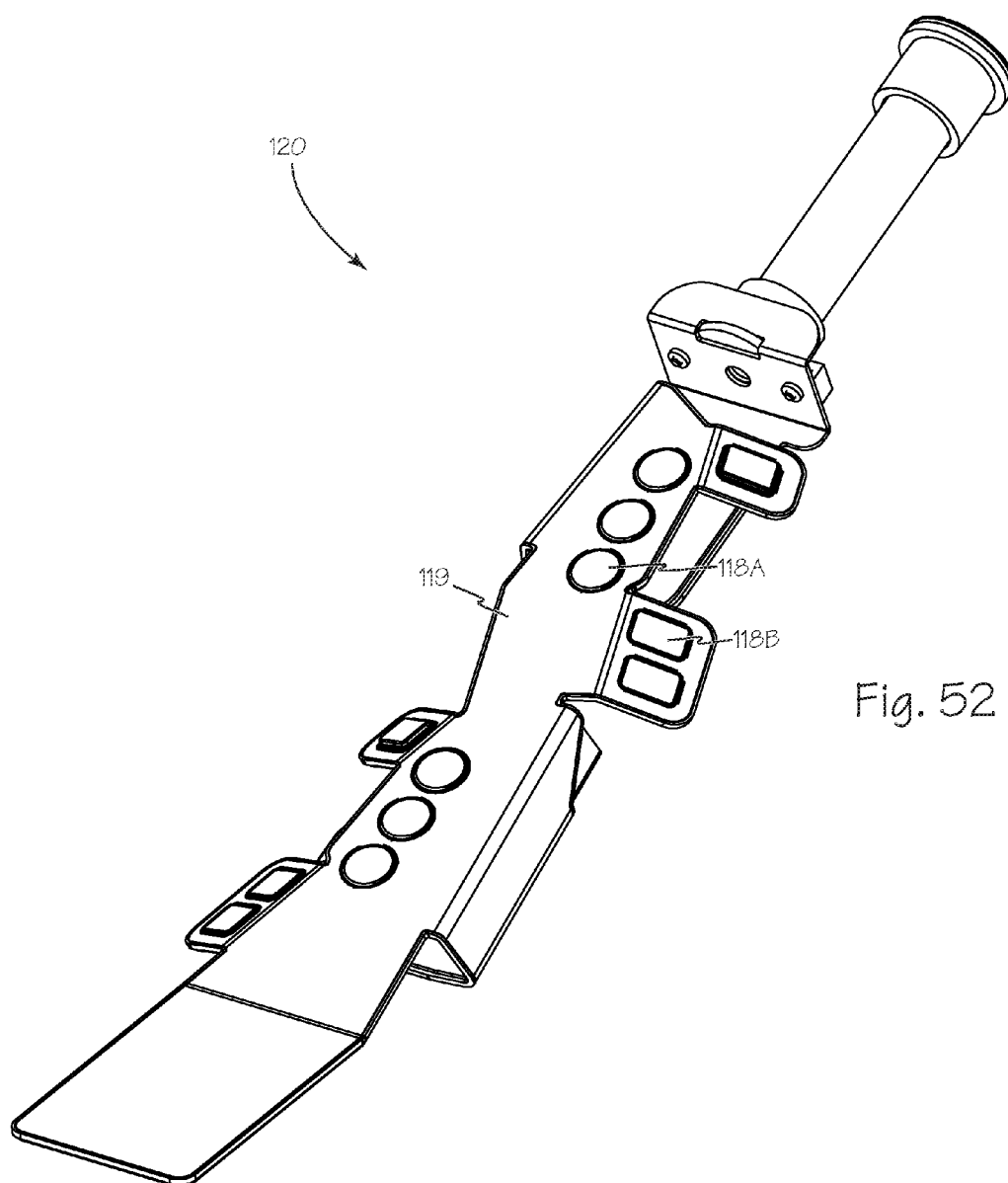

Fig. 52

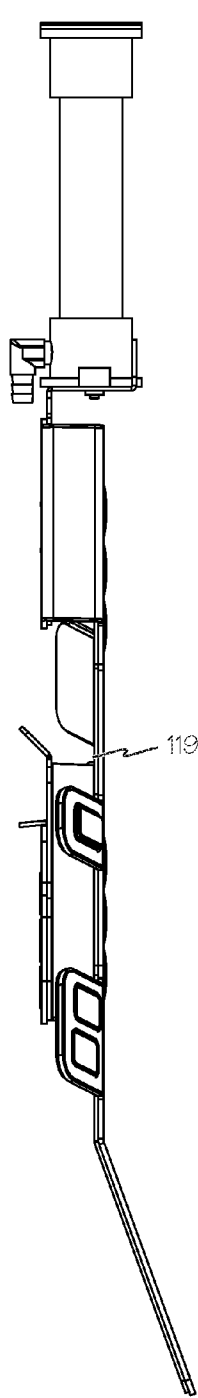

Fig. 54

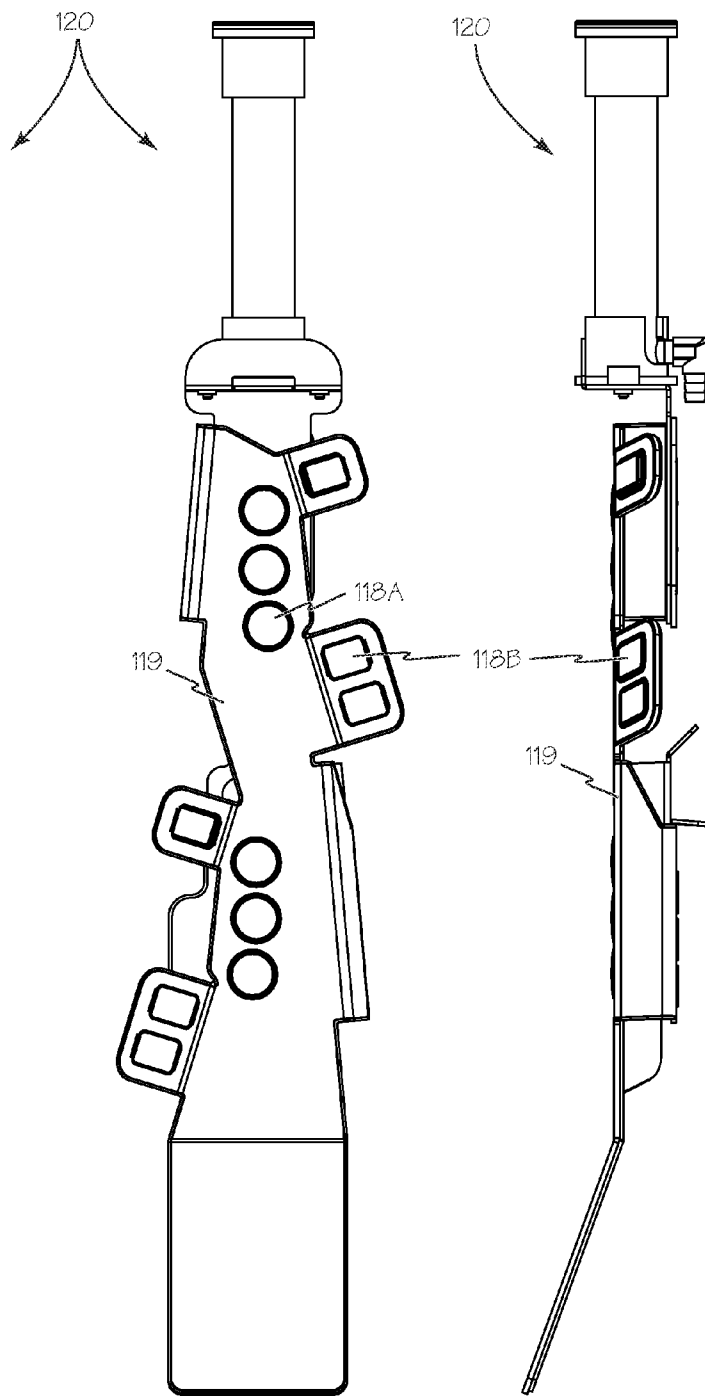

Fig. 53

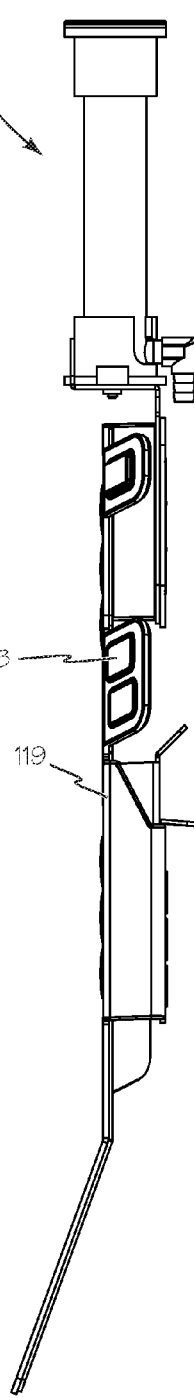
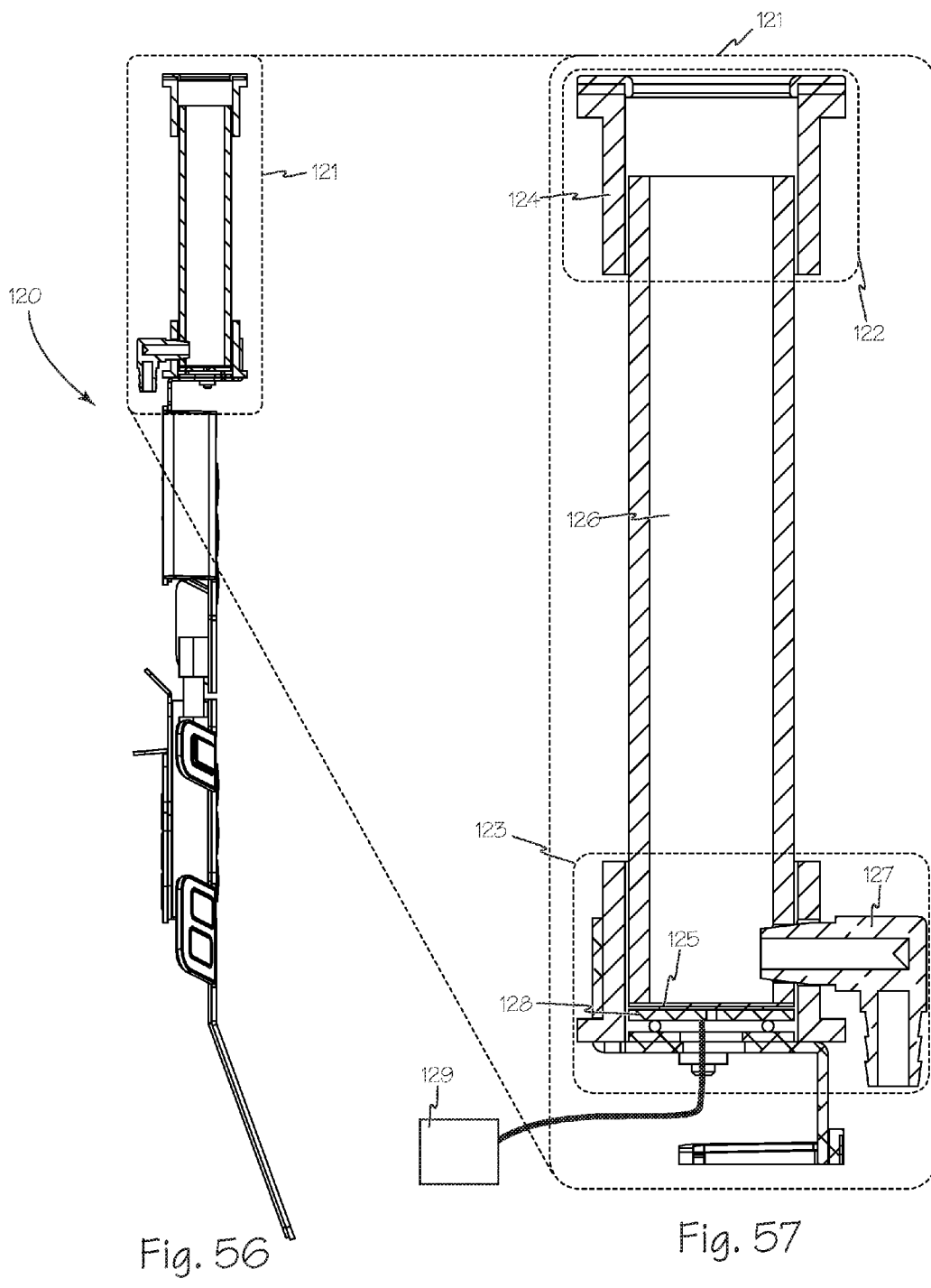
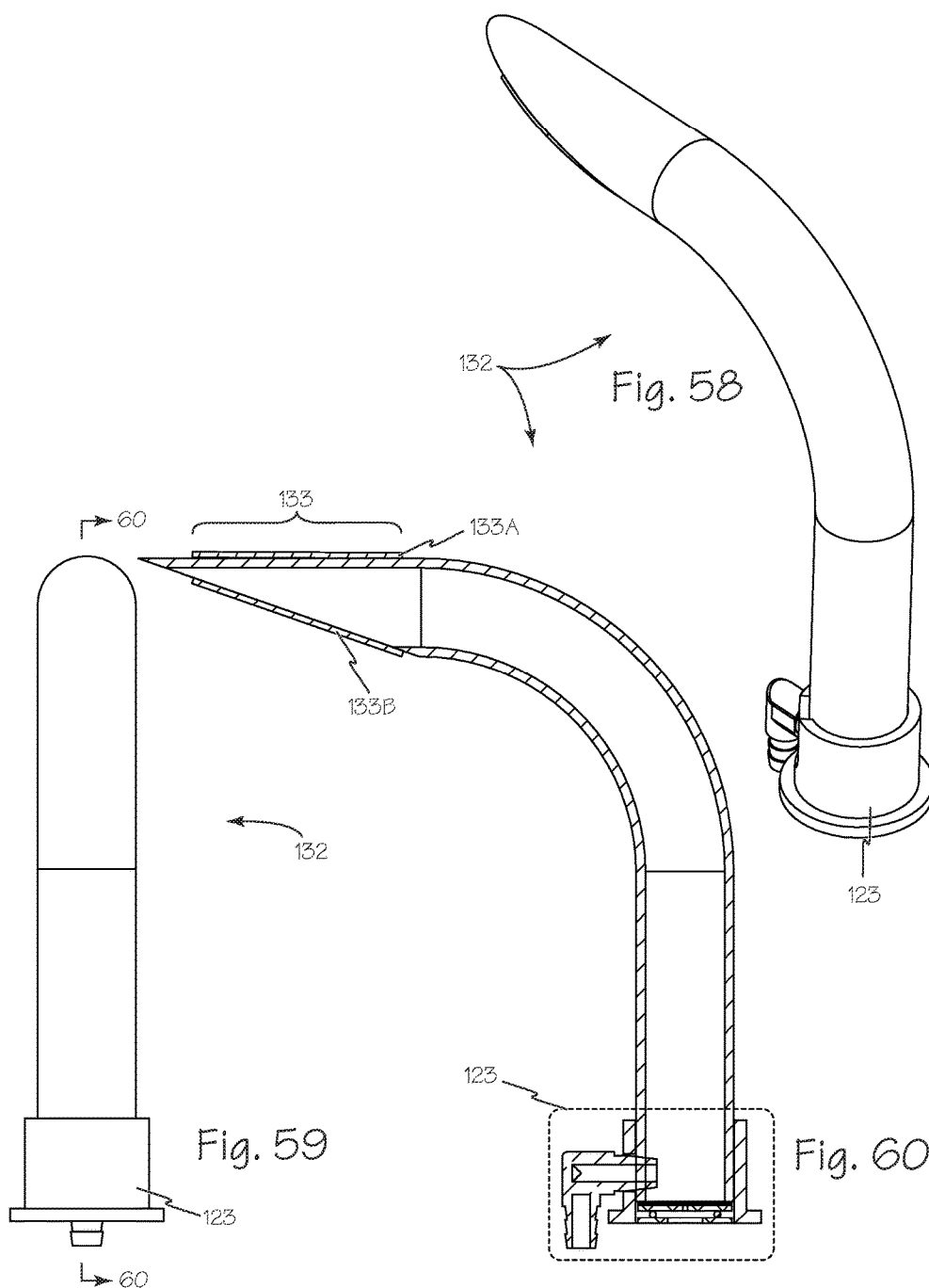

Fig. 55





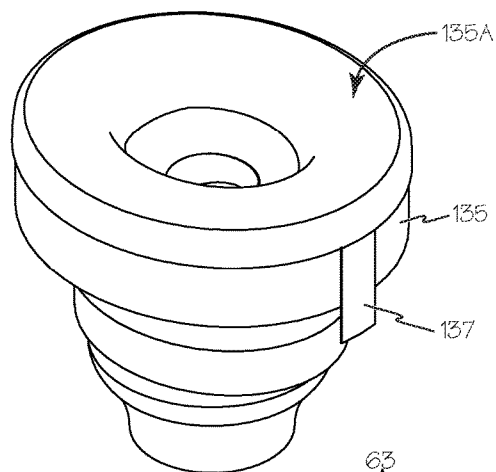

Fig. 61

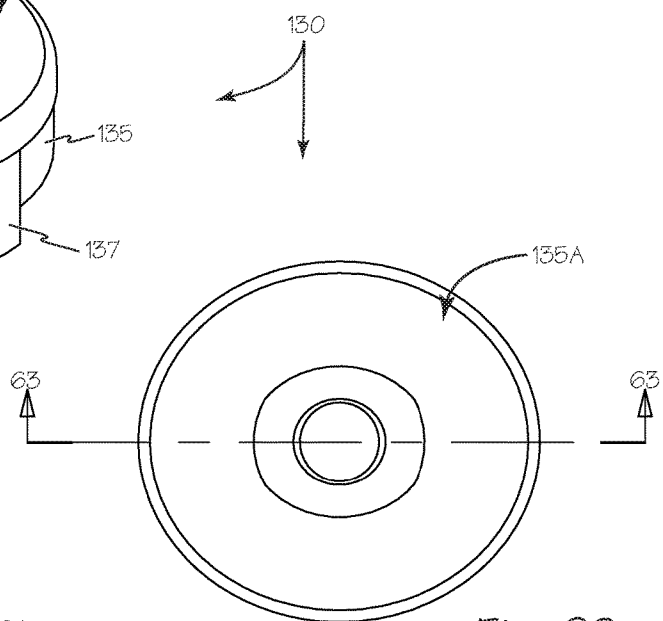

Fig. 62

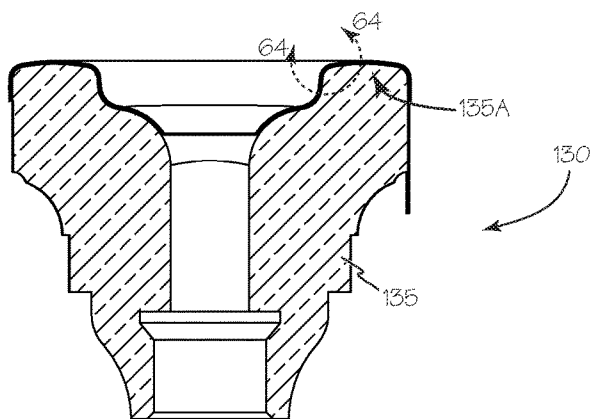

Fig. 63

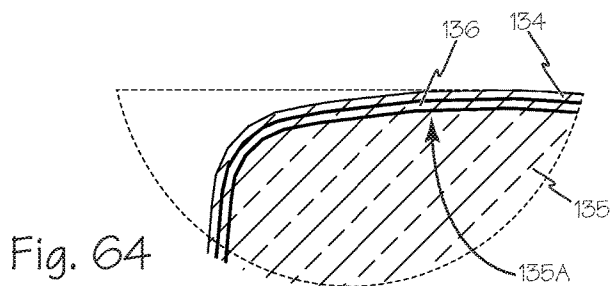
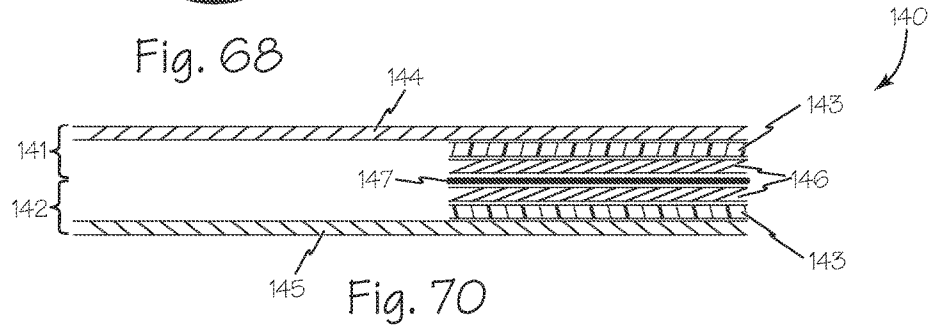
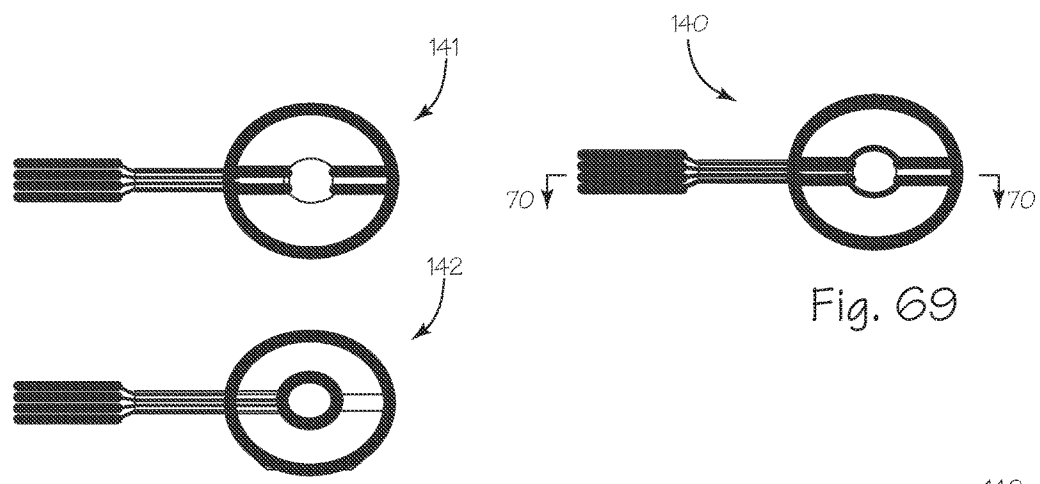
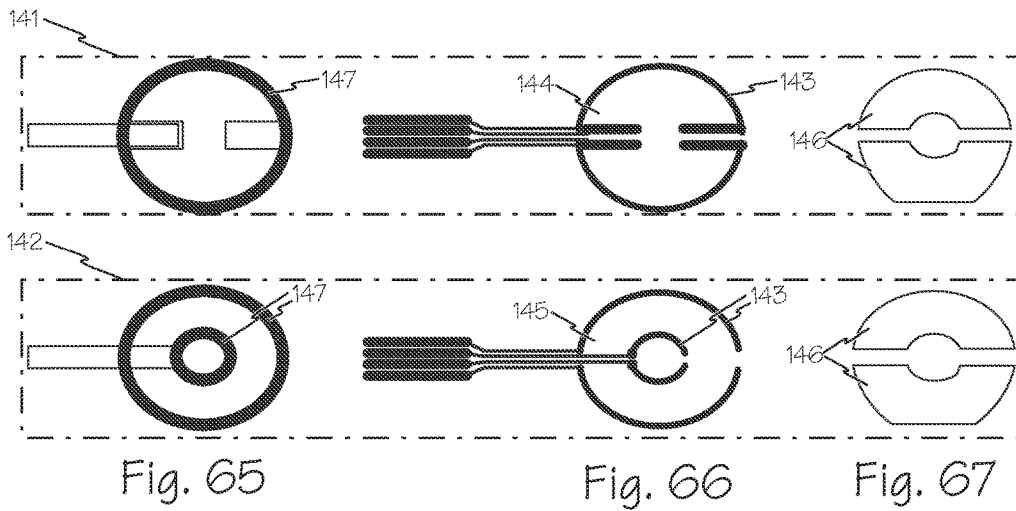

Fig. 64



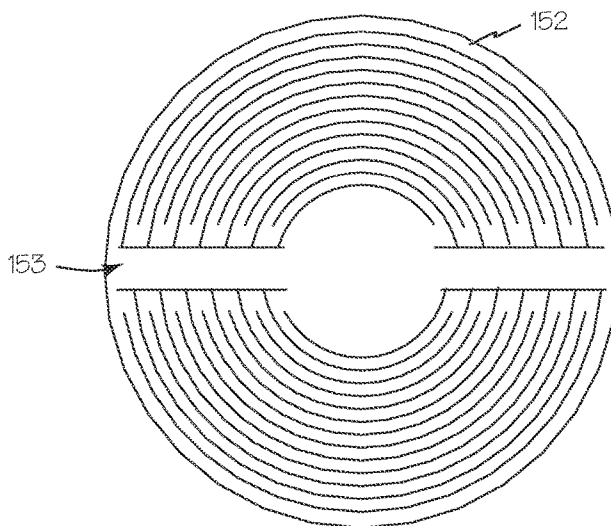

Fig. 71

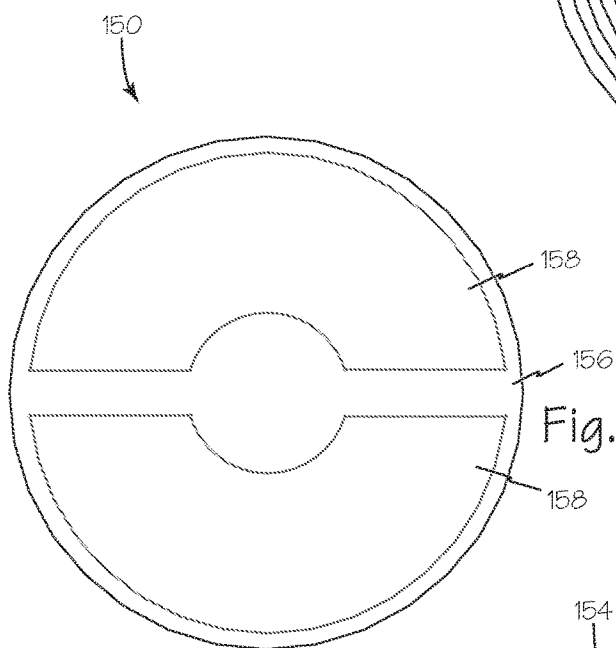

Fig. 72

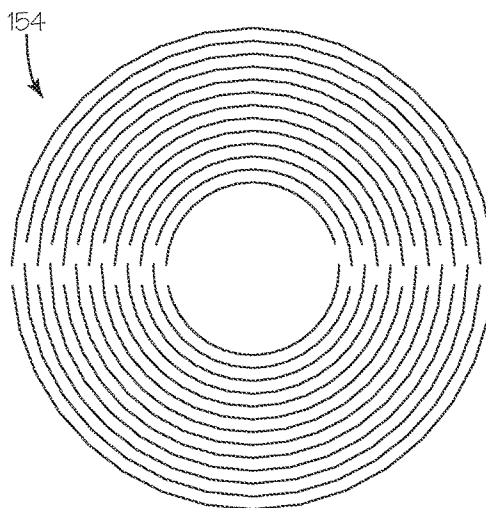

Fig. 73



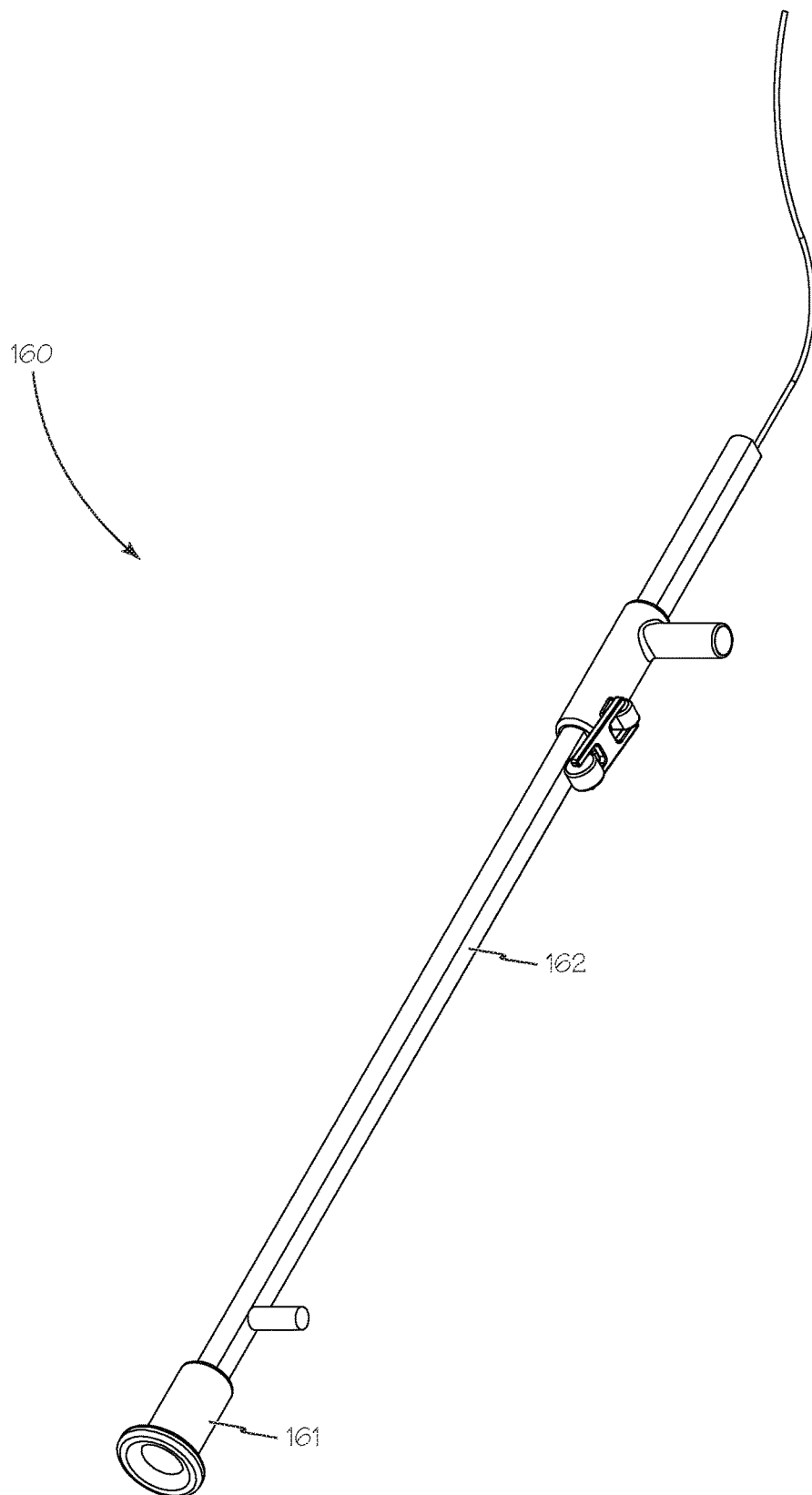

Fig. 74

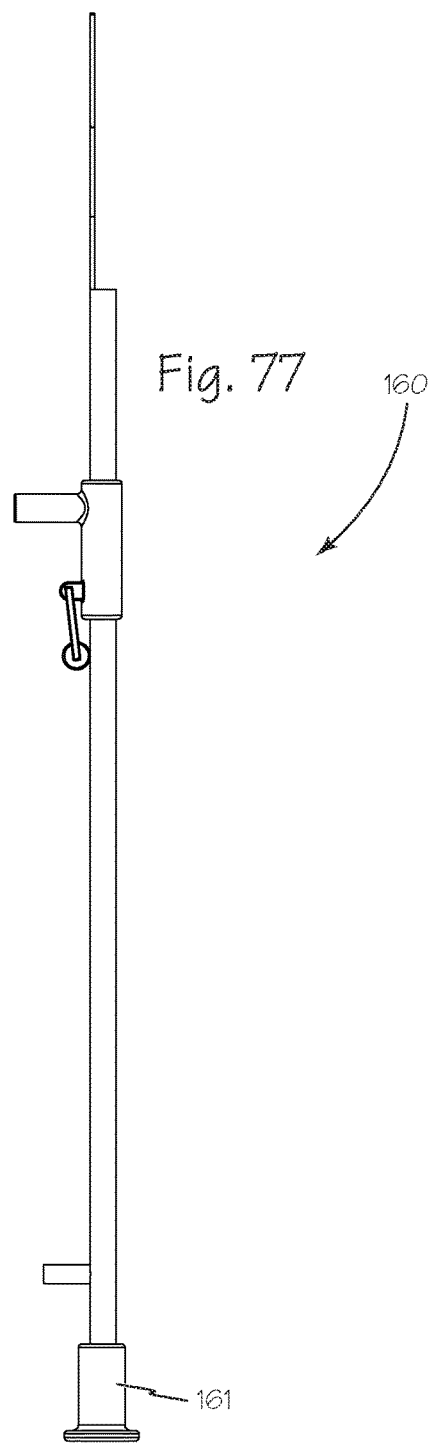
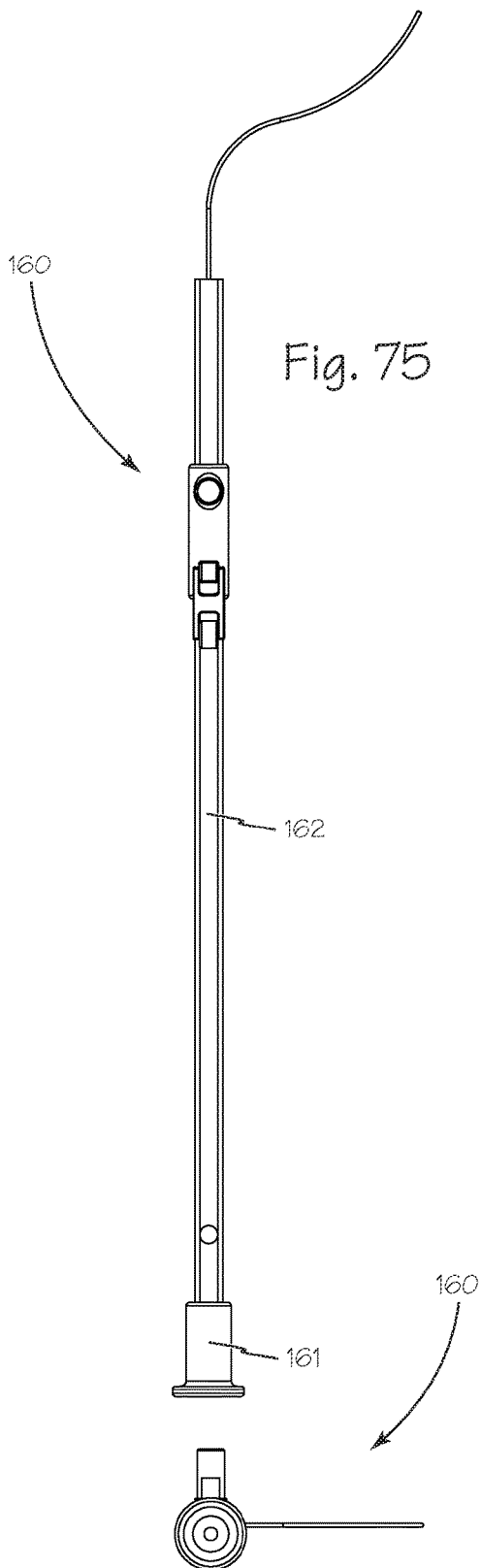

Fig. 76

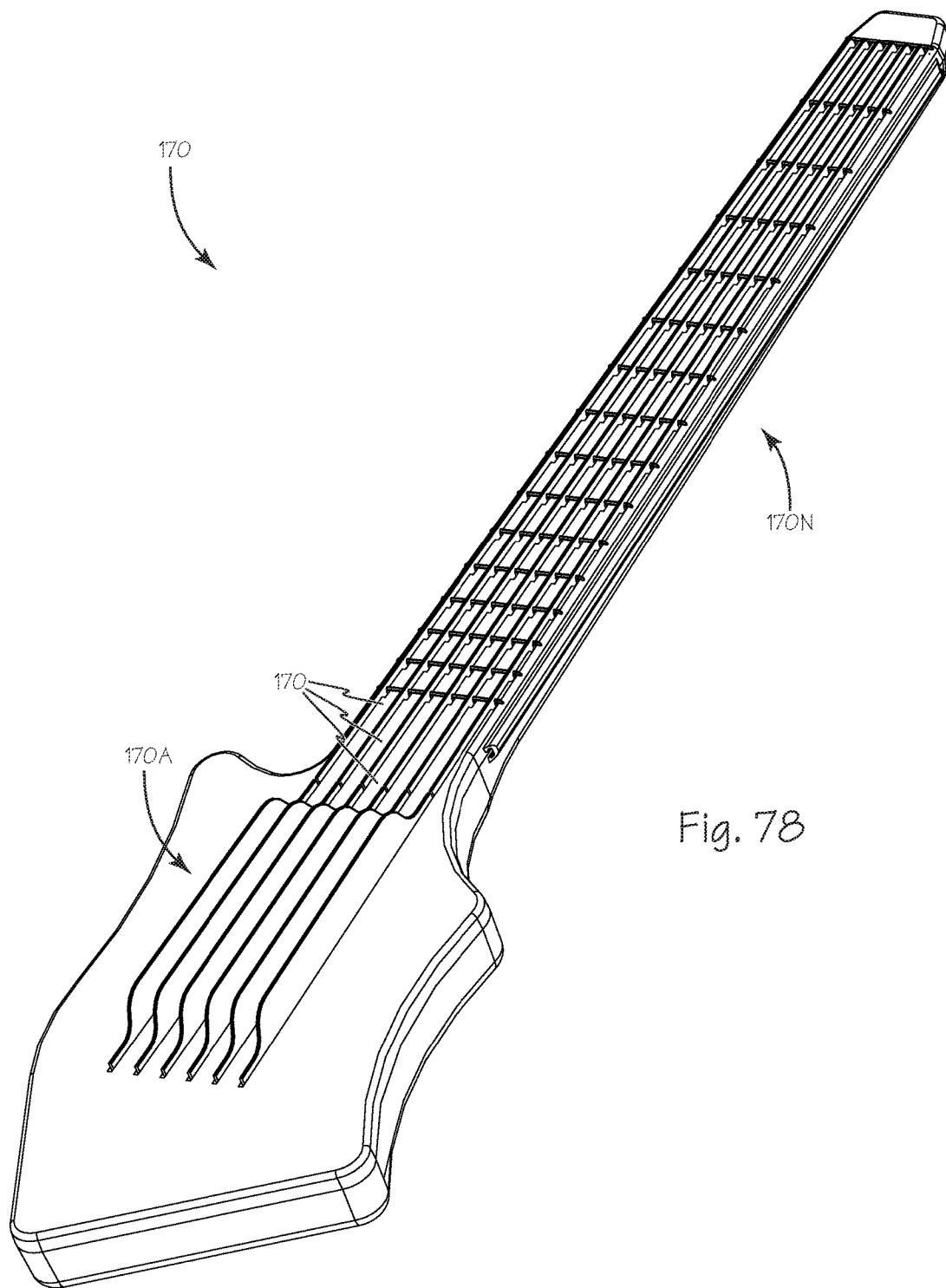

Fig. 78

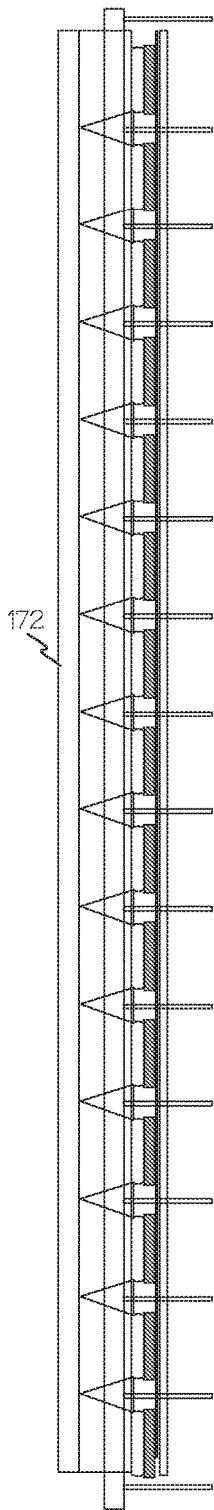

Fig. 80

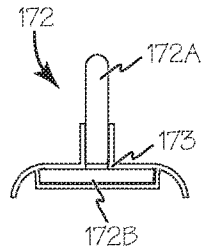

Fig. 81

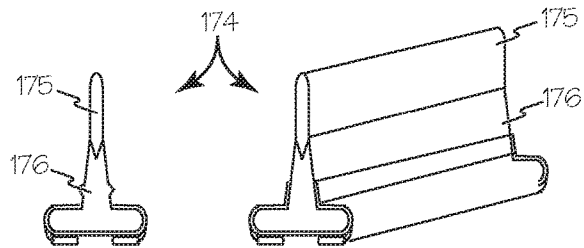

Fig. 82

Fig. 83

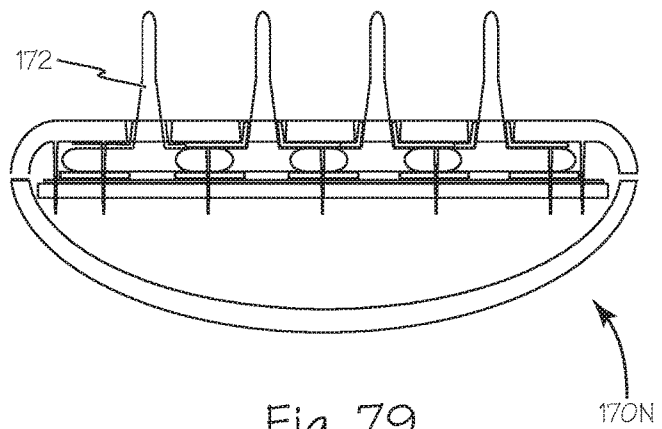

Fig. 79

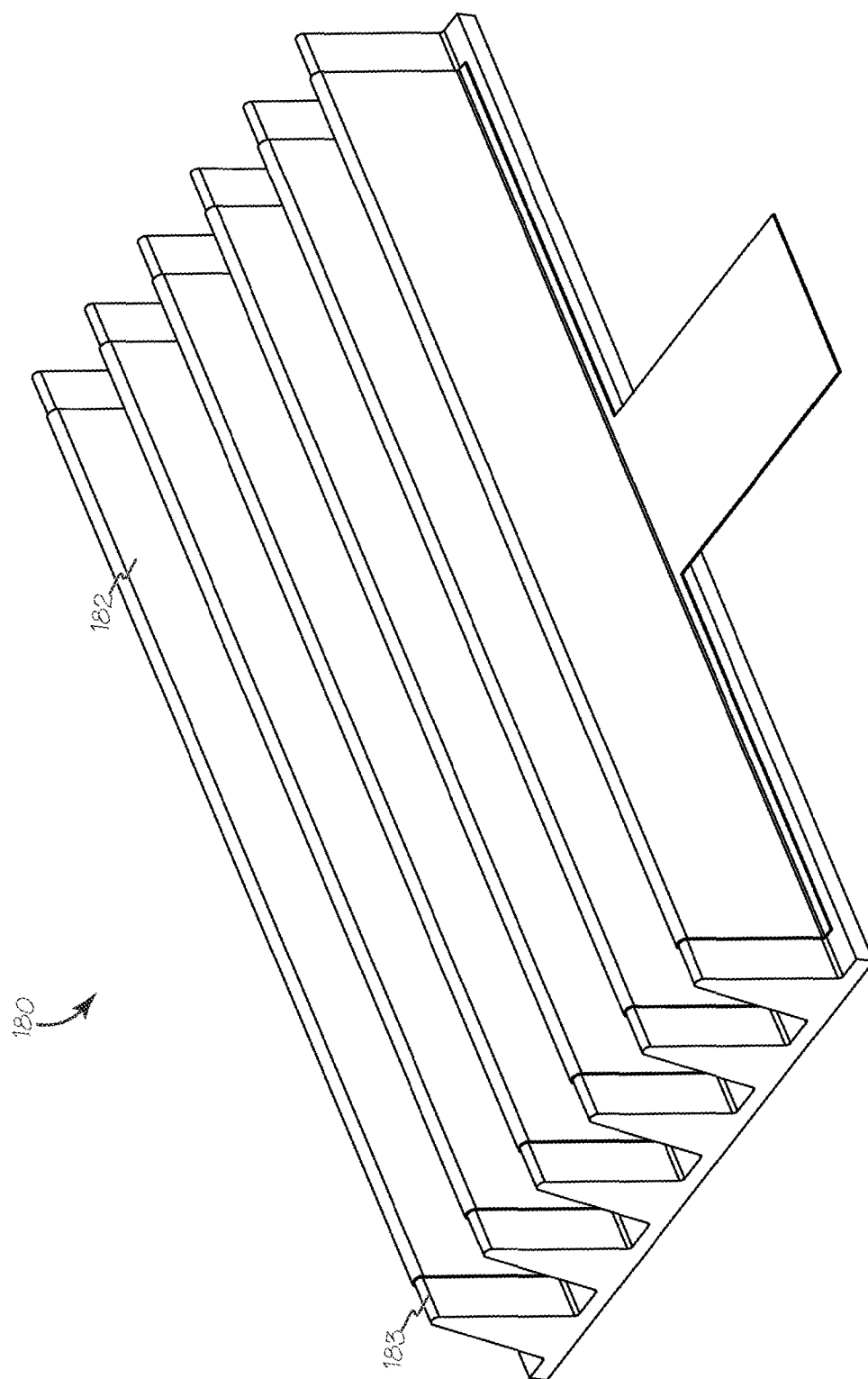
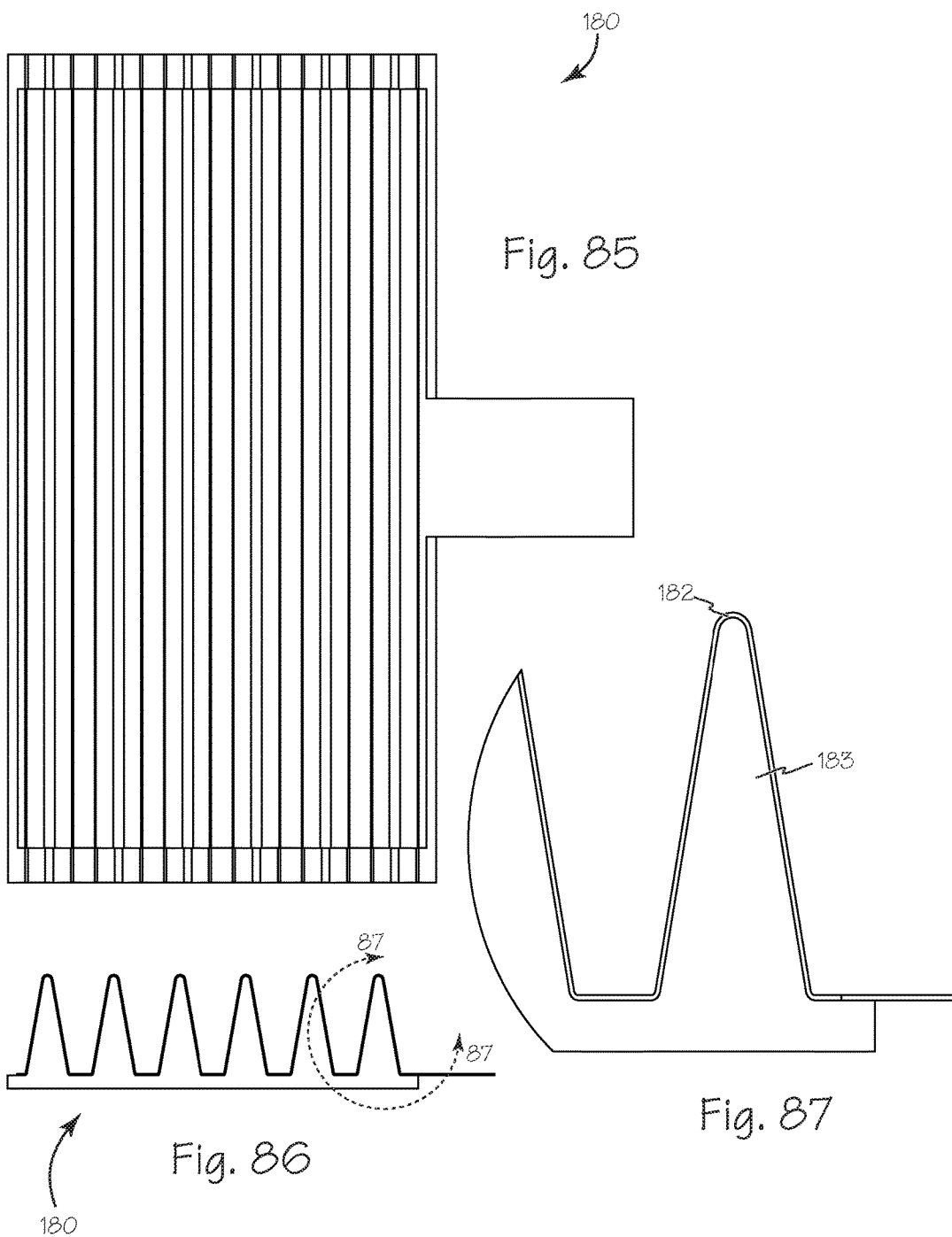

Fig. 84



**ELECTRONIC MUSICAL INSTRUMENTS**

## RELATED APPLICATIONS

This application is a continuation of U.S. patent application Ser. No. 14/949,652 filed Nov. 23, 2015 now U.S. Pat. No. 9,361,870 which is a continuation of U.S. patent application Ser. No. 14/667,426 filed Mar. 24, 2015, now U.S. Pat. No. 9,214,146 which is a continuation of U.S. patent application Ser. No. 14/216,803 filed Mar. 17, 2014, now U.S. Pat. No. 8,987,577 which claims priority from U.S. Provisional Patent Application 61/794,361 filed Mar. 15, 2013.

## FIELD OF THE INVENTIONS

The inventions described below relate the field of musical instruments and more specifically to the field of electronic musical instruments with force sensing resistor (FSR) sensors.

## BACKGROUND OF THE INVENTIONS

Conventional musical instruments are analog devices and the efforts to digitize instruments have been more ineffective except where the instruments have a key or valve for every different note such as a piano. The available electronic instruments suffer from one-dimensionality owing to the binary nature of their controls. For example, electronic guitars with vanes were divided into a strummer vane device and a neck system that worked together. The most blatant and detrimental feature of this approach was the non-tuned "noise" cause when the strummer vane was released.

## SUMMARY

The devices and methods described below provide for Electronic musical instruments with sensors to digitize and alter the sound using force sensing resistor (FSR) sensors in the mouthpieces and other elements of the instrument to mimic the variations available in analog instruments.

An FSR, either ShuntMode or ThruMode with an improved dynamic range may be created by adding a topography or texture to the surface of the conductor. This can be accomplished by both mechanical means as well as with additives to the ink formulation. Application of force to the substrate may generate any suitable texture or topography in the substrate.

Typically, a ShuntMode FSR consists of a substrate printed with highly conductive interdigitating finger trace patterns made of such conductive inks as silver or carbon, which is oriented in apposition to a substrate with FSR element printed and cured upon it. A ThruMode FSR is formed of highly conductive electrodes formed by deposition of inks such as silver or carbon which are deposited on two substrates that are overprinted with FSR elements. The two substrates of a ThruMode FSR are oriented in apposition with the substrates out and the printed FSR elements between the substrates.

The substrate of FSR sensors may be created using a suitable metalized plastic film such as Mylar® (Mylar® is a registered trademarks of DuPont Teijin Films U.S. Limited Partnership). By depositing aluminum on one or more surfaces of a plastic film sheet, large and inexpensive FSR sensors may be created. Plastic film sheets such as Mylar® may also be shaped to form suitable texture or topography

in the FSR substrate to improve the dynamic range of the sensor compared to sensors formed with smooth substrates.

## BRIEF DESCRIPTION OF THE DRAWINGS

FIG. 1 illustrates a front perspective view of a hybrid electronic guitar/piano.

FIG. 2 illustrates a rear perspective view of the hybrid electronic guitar/piano of FIG. 1.

FIG. 3 is an end view of the keyboard neck of the hybrid electronic guitar/piano of FIG. 1.

FIG. 4 is a top view of the keyboard neck of the hybrid electronic guitar/piano of FIG. 1.

FIG. 5 is an end view of the keyboard neck of the hybrid electronic guitar/piano of FIG. 1.

FIG. 6 is a side view of the keyboard neck of the hybrid electronic guitar/piano of FIG. 1.

FIG. 7 is a close up cross-section of the keyboard neck of FIG. 4 taken along 7-7.

FIG. 8 is a perspective view of the strum rods of the hybrid electronic guitar/piano of FIG. 1.

FIG. 9 is a front view of the strum rods of the hybrid electronic guitar/piano of FIG. 1.

FIG. 10 is an end view of the strum rods of the hybrid electronic guitar/piano of FIG. 1.

FIG. 11 is a side view of the strum rods of the hybrid electronic guitar/piano of FIG. 1.

FIG. 12 is a front view of an electronic music keyboard.

FIG. 13 is an end view of the electronic music keyboard of FIG. 12.

FIG. 14 is a side view of the electronic music keyboard of FIG. 12.

FIG. 15 is a close up cross-section of the keyboard of FIG. 14 taken along 15-15.

FIG. 16 is a close up cross-section view of an unactuated FSR button on any of the disclosed electronic instruments.

FIG. 17 is a close up cross-section view of a lightly actuated FSR button on any of the disclosed electronic instruments.

FIG. 18 is a close up cross-section view of a fully actuated FSR button on any of the disclosed electronic instruments.

FIG. 18X is a close up cross-section view of the components oriented for forming texture in a plastic film substrate.

FIG. 19 illustrates an electronic drum.

FIG. 20 is a perspective view of an electronic guitar.

FIG. 21 is a side view of the electronic guitar of FIG. 20.

FIG. 22 is a close-up view of a portion of the neck of the electronic guitar of FIG. 21 taken along 22-22.

FIG. 23 is a perspective view of an FSR rocking bridge for the electronic guitar of FIG. 20.

FIG. 24 is a front view of the rocking bridge of FIG. 23.

FIG. 25 is a close up cross-section view of the rocking bridge of FIG. 22 taken along 25-25.

FIG. 26 is an end view of the rocking bridge of FIG. 23.

FIG. 27 is a front view of the FSR pads for the rocking bridge of FIG. 23.

FIG. 28 is a front view of the conductor traces for the rocking bridge of FIG. 23.

FIG. 29 is a front view of a continuous string simulator for an electronic guitar.

FIG. 30 is an end view of the FSR continuous string simulator of FIG. 29.

FIG. 31 is a close-up view of a portion of the FSR continuous string simulator view of FIG. 30 taken along 31-31.

FIG. 32 is a perspective view of the FSR continuous string simulator of FIG. 30.

3

FIG. 33 is a close-up view of a portion of the FSR continuous string simulator view of FIG. 32 taken along 33-33.

FIG. 34 is a perspective view of an alternate continuous string simulator for electronic string instruments.

FIG. 35 is a perspective view of the suspension system and vanes for the continuous string simulator of FIG. 34.

FIG. 36 is a front view of the suspension system and vanes for the continuous string simulator of FIG. 34.

FIG. 37 is an end view of the suspension system and vanes for the continuous string simulator of FIG. 34.

FIG. 38 is a side view of the suspension system and vanes for the continuous string simulator of FIG. 34.

FIG. 39 is a front view of the continuous string simulator of FIG. 34.

FIG. 40 is a side view of the continuous string simulator of FIG. 39.

FIG. 41 is an end view of the continuous string simulator of FIG. 39.

FIG. 42 is a perspective view of a vane for the continuous string simulator of FIG. 34.

FIG. 43 is a front view of a vane for the continuous string simulator of FIG. 34.

FIG. 44 is a side view of a vane for the continuous string simulator of FIG. 34.

FIG. 45 is an end view of a vane for the continuous string simulator of FIG. 34.

FIG. 46 is a perspective view of the substrate for a continuous string simulator with vanes oriented for use.

FIG. 47 is a front view of the substrate of FIG. 46 with rubber pads.

FIG. 48 is a side view of the substrate of FIG. 46 with rubber pads.

FIG. 49 is a perspective view of an electronic bow.

FIG. 50 is a side view of the electronic bow of FIG. 49.

FIG. 51 is a close-up view of a portion of the electronic bow view of FIG. 50 taken along 51-51.

FIG. 52 is a perspective view of an electronic wind instrument.

FIG. 53 is a front view of the electronic wind instrument of FIG. 52.

FIG. 54 is a right side view of the electronic wind instrument of FIG. 52.

FIG. 55 is a left side view of the electronic wind instrument of FIG. 52.

FIG. 56 is a cross-section view of an electronic mouthpiece for brass and wind instruments.

FIG. 57 is a close-up view of the mouthpiece of FIG. 56.

FIG. 58 is a perspective view of a saxophone style mouthpiece for the electronic wind instrument of FIG. 52.

FIG. 59 is a front view of the mouthpiece of FIG. 58.

FIG. 60 is a cross-section view of the mouthpiece of FIG. 59 taken along 60-60.

FIG. 61 is a perspective view of an alternate purse style mouthpiece

FIG. 62 is a top view of the mouthpiece of FIG. 61.

FIG. 63 is a cross-section of the mouthpiece of FIG. 62 taken along 63-63.

FIG. 64 is a close-up of the cross-section of the mouthpiece of FIG. 63 taken along 64-64.

FIG. 65 is a front view of dielectric layers for the X and Y thru mode circuits of the mouthpiece of FIG. 61.

FIG. 66 is a front view of conductor layers for the X and Y thru mode circuits of the mouthpiece of FIG. 61.

FIG. 67 is a front view of FSR layers for the X and Y thru mode circuits of the mouthpiece of FIG. 61.

4

FIG. 68 is a front view of compiled layers for the X and Y thru mode circuits of the mouthpiece of FIG. 61.

FIG. 69 is a front view of assembled layers for the thru mode sensor for the mouthpiece of FIG. 61.

FIG. 70 is a cross section of the assembled thru mode sensor of FIG. 69 taken along 70-70.

FIG. 71 is a front view of the conductors for a shunt mode sensor for the mouthpiece of FIG. 61.

FIG. 72 is a front view of the resistor shunt layer for a shunt mode sensor for the mouthpiece of FIG. 61.

FIG. 73 is an alternate conductor layout for a shunt mode sensor for the mouthpiece of FIG. 61.

FIG. 74 is a perspective view of an electronic trombone.

FIG. 75 is a front view of the electronic trombone of FIG. 74.

FIG. 76 is an end view of the electronic trombone of FIG. 74.

FIG. 77 is a side view of the electronic trombone of FIG. 74.

FIG. 78 is a perspective view of an alternate electronic guitar.

FIG. 79 is a cross-section view of the neck of a four-string configuration of the alternate guitar of FIG. 78.

FIG. 80 is a side view of the vanes of the alternate guitar of FIG. 78.

FIG. 81 is an end view of a vane for the alternate guitar of FIG. 78.

FIG. 82 is an end view of an alternate vane for the guitar of FIG. 78.

FIG. 83 is a perspective view of the alternate vane of FIG. 82.

FIG. 84 is a perspective view of a portion of an alternate FSR fretboard for an electronic guitar.

FIG. 85 is a front view of the alternate FSR fretboard of FIG. 84.

FIG. 86 is an end view of the alternate FSR fretboard of FIG. 84.

FIG. 87 is a close-up cross section of a portion of the alternate FSR fretboard of FIG. 86 taken along 87-87.

#### DETAILED DESCRIPTION OF THE INVENTIONS

The Guitano, electronic instrument 1 of FIGS. 1-11 includes a 3 octave range, piano-like keyboard 2 incorporated into a guitar-style neck 3 with two or more guitar-like strum-rods in strum rod assembly 4 on body 5 of the instrument. There are two types of keys that may be used. The first key, pressure key 8, measures only force applied to each key. Second key, FSR key 6 measures contact in 3-axes, X-axis 18, Y-axis 17 and Z-axis 19, or position and force sensing using trampoline keys such as key 6 on the neck. The 3-axis FSR sensors in the keys determine exact location and force of the fingers. The keys respond to the user's touch inflections allowing for expression of effects like vibrato, note bending or cross fading voices, as well as determining the volume of a note. User input keys such as key 7 are used to set up how the keys respond to position/force information and how the Strum-rods are used.

Referring now to FIG. 8, each strum-rod such as strum-rod 10 is supported by rocker towers 12 which are pivotally supported by pivot pins 13 in first pivot blocks 14A and 14B along with second pivot blocks 16A and 16B. Depending which end of the strum-rod is strummed, along y-axis 17, and which direction the force is applied to the strum-rod, along x-axis 18 and z-axis 19, will control the performance of the instrument.



The user determines how a note is played using either key mode, strum mode or a combination of both modes simultaneously. In the key mode, electronic instrument **1** operates as a regular keyboard that is mounted on a guitar-style body. In key mode a note is sounded when the key is activated or struck and strum-rod assembly **4** can be used to modify the note that has already been sounded. The strum-rods trigger and control the volume of whatever notes are pressed on the neck. In strum mode, a note is sounded only after a strum-rod is released and depends on the strum-rod or rods that are strummed. In "Both" mode the keys sound off immediately but will repeat when every time the strum-rods are activated.

Depending on the user settings, the strum-rods can produce different notes and effects. For example, operating one strum-rod could produce only the note[s] pressed on the keyboard neck but operating two or more strum-rods might produce the notes pressed on the neck as well as their fifths or octaves, allowing a chord to be made out of one key and a few strummers being operated or strummed. Also, resting your hand on the strummer could act as a mute, adding to the expressive capabilities. Mute collars **15** may be included between the strum rods and the rocker towers to optimize the mute capabilities of the instrument. Mute collars **15** may be made of rubber, polymers or any other suitable materials.

Another possible use of strum-rod assembly **4** is: one note on the neck will produce five octaves of that note, two notes held on the neck will produce those two notes in two octaves, three notes on the neck could produce the three notes held down with the root note in octaves, four notes held down will produce four notes and octave, and five notes down will produce five notes.

Keyboard instrument **20** of FIGS. **12** through **15** is a musical instrument that functions as a regular keyboard but with greater responsiveness and expressive capabilities. There are two versions; one simply senses the amount of force applied to each key such as key **21** to determine amplitude of the note. Alternatively, keys such as FSR key **24** may be equipped with 3-axis sensors to allow the instrument to detect exact position and force applied to each individual key. Sliding up and down on a key such as FSR key **24** may produce various effects such as cross-fading between two different music voice sets, while rocking side to side could act as a wah-wah or other effect. The pressure applied to keys such as key FSR **24** may be used to control the amplitude of the note produced.

Keyboard instrument **20** includes a microprocessor **25** to interpret each note as force is applied to a key. The note's sustain may take different characteristics based on how the key is manipulated after force is first applied.

Each 3-axis key such as FSR key **24** can be a single entry XYZ pad and features a trampoline sensor **26** illustrated in FIGS. **15** through **18**. Trampoline sensor **26** increases the travel of switch/sensor layers **27** and minimizes the hard feel at the end of travel. A trampoline sensor achieves this with an opening **28** in rigid substrate **29** that outlines the shape of the switch/sensor.

Key position signals such as signal **30** corresponding to the position and force applied each key are applied to microprocessor **25**. Microprocessor **25** receives and interprets key position signals such as signal **30**. Position and force sensing element within a key may be configured to operate as a linear pot which can be assigned such parameters as note bend and pass that value to microprocessor **25**. A body brace and neck strap may be included to support any of the disclosed electronic instruments, such as keyboard **20**, in place while the operator is dancing with the music. Control Parameters may be configured with—Up/down—

Right/Left—Enter—touch sensing user input keys **31** to change any program parameters like voice or key functions.

Keyboard instrument **20** functions most simply as a typical keyboard, but with many expanded options. The XYZ sensing capacity of each key can interpret finger movement **32** within perimeter **33** of each key to allow for greater expression such as vibrato or pitch bend for each individual key while applied force **34** can be read to interpret the volume of a note. The linear pot configuration may be used as a "ribbon controller" and assigned any input for functions like global pitch bend or EQ shifting. The Up/down—right/left—Enter function keys are FSR keys and are used to change the any function such as how keys respond to finger position, assignment to the linear pot, as well as changing the voice of the instrument.

Keyboard instrument **20** may also be configured with FSR sensors formed as a matrix array. A first substrate includes many parallel conductors with an resistive layer deposited on the conductors. A second substrate includes many parallel conductors with an resistive layer deposited on the conductors. The first substrate is oriented in apposition to the second substrate with the conductors of the first substrate perpendicular to the conductors of the second substrate. Application of a force to any point of the properly oriented layers results in signals from the conductors on the first substrate and the second substrate corresponding to the point the force was applied with the signal level corresponding to the intensity of the force applied.

FSR sensors benefit from a trampoline configuration such as illustrated in FIGS. **15**, **16**, **17** and **18**. Force sensor **26** is formed with two parallel substrates such as first and second substrates **27A** and **27B**. Each substrate may be planar or may be shaped to form one or more flexible sections such as shaped sections **38A** and **38B** to optimize sensor movement along the z-axis. Each substrate contains one or more FSR elements, such as conductive deposits and or traces **40A** and **40B** respectively, to form a force sensing resistor to quantify the location and intensity of force, such as force **34** applied to the active area within perimeter **33** of each key sensor. Sensor support or substrate includes openings such as opening **28** sized and dimensioned to correspond to the active area within perimeter **33** of the force sensor **26**.

FSR sensor **26** may be formed with the force sensing elements on each substrate, **40A** and **40B** respectively, oriented in apposition to provide one or more different active areas or a single active area corresponding to the area within perimeter **33**.

FSR sensor **26** of FIG. **16** is experiencing minimal z-axis force **34A**. As z-axis force **34B** increases as illustrated in FIG. **17**, shaped section **38A** flexes more than shaped section **38B** bringing first and second FSR conductive layers **40A** and **40B** into contact initiating a measurable response from sensor **26**. As the intensity of z-axis force **34C** increases as illustrated in FIG. **18**, shaped section **38B** contacts lower surface **28** of the substrate opening. In fully depressed mode as illustrated in FIG. **18**, first and second FSR conductive layers **40A** and **40B** are in full contact and a correspondingly low resistance between the conductive layers.

An FSR sensor may be configured as either ShuntMode or ThruMode with an improved dynamic range may be created by adding a topography or texture to the surface of the conductor. This can be accomplished by both mechanically forming texture or topography on the substrate as well as with additives to the ink formulation. Any suitable texture or topography in the substrate will produce improvements in dynamic response compared to a smooth substrate. Using metallized plastic film sheets as a substrate, substrate **27A**,

with a coating **40A** formed of deposited aluminum instead of silver or other expensive conductor enables production of inexpensive FRSs in volume. Texture may be applied to a substrate such as substrate **27A** by pressing the uncoated plastic sheet substrate with, for example, sandpaper. The irregularities in the surface of the sandpaper transfer to the substrate and after deposition of the aluminum conductor, the conductor contact surface **41** includes sufficient surface irregularities to operate as an FSR sensor with a high dynamic response.

Typically, a ShuntMode FSR consists of a substrate printed with highly conductive interdigitating finger trace patterns made of such conductive inks as silver or carbon, which is oriented in apposition to a substrate with FSR element printed and cured upon it. Or in the case of the ThruMode, highly conductive electrodes of such inks as silver or carbon are deposited on both substrates that are overprinted with FSR elements. The silver conductive inks demonstrate more “standoff” and dynamic range than the carbon conductor due to the topography caused by the silver flakes and lack of topography of the micro carbon particles.

An experiment was performed comparing the resistance characteristics of the FSR before and after adding texture or topography to the plastic substrate. In the case of the ShuntMode, either of the substrates with the conductive fingers or the substrate with the FSR could be textures for the desired results. For the ThruMode construction, to minimize the topography of conductive base inks like silver or carbon that have a surface topography when printed, metallized Mylar® was used because the vacuum deposited aluminum surface was relatively flat. Adding roughness to the substrate increased the dynamic range, increased the FSR resistance at any given amount of force, and increased the standoff (minimum force required to begin actuation).

A rough texture/topography may be formed in a plastic film substrate in the process illustrated in FIG. **18X**. The plastic film substrate such as substrate **27A** or **27B** is sandwiched between a sheet of sandpaper **43** and a sheet of rubber **45**. Pressure is applied to the sandpaper with adjustable roller nips **46**. As a result, the sand particles **43X** of sandpaper **43** create indentations in one surface of the plastic film substrate, and tiny raised bumps on the other surface of the plastic film substrate. Alternatively, the desired texture/topography may be etched into a suitable roller which may be used to impress the desired texture/topography into the plastic film substrate.

The changes in the FSR performance characteristics are a result of a micro points of contact between the FSR (either ShuntMode or ThruMode) sheet and the mating substrate caused by the topography or bumps on the surface of the substrate. As a result, a higher amount of force is required to bring the surfaces into contact, and a higher amount of force is required to produce equivalent levels of resistance.

It has been observed that the dynamic range of the sensor is affected if the substrate is textured by mechanical means before or after the FSR element is printed and cured. The graph shows a control part, a part with the FSR printed over a textured surface, and texturing the surface after the FSR element is printed and cured. Printing first and then texturing yields more dramatic dynamic range. Also, when the surface is textured after the FSR is printed and cured, the tips of the raised FSR forms actually stretch the FSR element making the tips more resistive thereby increasing the dynamic range and adding more linearity to the initial contact. This is a desired feature, to minimize the rapid or sharp response or quick knee of the curve with additional linearization as initial force is applied.

Alternatively, a semi-conductive additive such as silicon carbide or iron oxide particles of particular sizes are added to the FSR ink causing raised particles. Spherical semi-conductive or dielectric micro particles of controlled sizes have been found to contribute in achieving desired linearity and other force/resistance curve control parameters. When cured the particles stand proud of the base ink causing multiple micro peaks in the FSR element. The changes in the FSR characteristics are a result of a micro points of contact between the FSR (either ShuntMode or ThruMode) sheet and the mating substrate caused by the bumps on the surface of the substrate. As a result, a higher amount of force is required to bring the surfaces into contact, and a higher amount of force is required to produce equivalent levels of resistance. In addition to creating a larger dynamic range across the entire spectrum, these micro-bumps greatly increase useful data from initial contact.

Electronic drum **50** of FIG. **19** has discrete strike zones such as strike zones **51**, **52** and **53** designed with rubber pad over multiple-zoned FSR sensors for tabletop playing. Electronic drum **50** is also formed to fit between the player’s legs or in their lap like a bongo, or worn marching band-like with a strap which may be hung from around the neck with a removable body brace **54** so the player can dance with the music. It can be played anywhere. One or more linear pots are included in the design to allow the user to modify the tone or other programmable parameters of the drum.

As discussed above, the keys and strike zones on the Electronic drum are available in two versions; one the senses only the intensity of force applied to a key or strike zone. The other style sensor senses 3-axis force application or position and force sensing for each keys and strike zones. The sensors respond to the user’s strike inflections allowing for expression of effects like EQ or voice change as well as determining the volume of the note.

Velocity and position control in each strike zone pad measure the intensity of applied force as well as position. Rubber over sensor for comfortable hand drum playing, or playing with sticks. Included in the design is a body brace support for wearing with a neck strap.

Each pad is discrete and can respond independently to a hit. There are one or more linear pots that are user programmable and can be used to change the pitch of voice or other characteristics. The sensors are covered in rubber to reduce acoustically projected sound from the instrument and for hand-drum playing comfort, and to extend the life of the sensors when struck with sticks. The Up/Down—Right/Left—Enter function control keys are FSR keys and are used to change and navigate any function such as how keys respond to finger position, assignment to the linear pot, as well as changing the voice of the instrument. There is a collapsible thigh brace that triggers a Squeeze sensor for playing while sitting.

An Electronic guitar or Syntar such as Electronic guitar **60** illustrated in FIGS. **20** through **43** is a six string acoustic/electronic hybrid guitar which includes controller **61** that can produce output signals corresponding to audio string excitement such as volume after the string is released. It also will produce a signal proportional to the amount of pitch bend in the neck, or whether the string is strummed up or down with the use of RockingBridge sensor assembly **63**. Fretboard **64** uses linear pots **65** for each string **66** for calibrated pitch or frequency positions. Each linear pot such as linear pot **65** are flanked with FSR sensors such as FSR sensors **67** and **68** each side of each linear pot to establish force sensing and to assist in note bend determination amount. The combination of RockingBridge **63** coupled

with the linear pot/FSR aid in the interpretation of all gestures or emotional expressions applied to each string in conjunction with the strumming or other activation of the strings **66**. This expressive combination also facilitates the hammer-on note excitement.

Strings **66** are strung with typical guitar mechanism like an adjustable string anchor **69** at distal end and mechanical tuning peg **70** at the proximal end of strings **66**. Once strings **66** are stretched over RockingBridge sensor assembly **63** and in position they demonstrate good intonation.

Referring now to FIGS. **23-28**, strings **66** are stretched over RockingBridge-Sensor assembly **63**. The RockingBridge Sensor assembly **63** is located in the position prescribed for the bridge to maintain a correct tonal scaling and includes an FSR sensor such as FSR sensors **71** for each string. Strumming along X-axis **72**, perpendicular to the strings **66** and Y-axis **73** can be detected by use of two discrete FSR elements **71A** and **71B**. Each discrete FSR element is located under each side of each RockingBridge string support such as support actuators **74**.

Adjustable string anchor **69** is adjusted so that just enough, but not too much force is applied to each RockingBridge Sensor such as sensors **71** to sound a good tone and to derive the widest dynamic range when strings **66** are strummed, plucked, or bent. If additional offset is required to balance optimal string tension and optimal string force applied to sensors **71**, spacers may be inserted between the FSR membrane layers to offset RockingBridge sensor assembly **63**.

Referring now to FIG. **22**, fretboard **64** is composed of membrane **64M** with one or more LinearPots **65** under each string and establishes the “virtual fret” location or the location may be determined using discrete resistor pads **76** beneath the strings. Two notes positions can be achieved [essentially] simultaneously by reading the LinearPot fixed resistor value of the from each end. The Electronic virtual note value for a string is detected by the position on the LinearPot. Audio note output is achieved by pumping voltage from a biasing resistor directly to an amplifier. The string expression is derived by both the force applied to the RockingBridge sensor and by the FSR LinearPot of the neck. A note is not activated until the string is released. The further the string is pulled back and released the louder the note will be sounded. Hammer-On notes are achieved by simply striking a note position on the neck.

To simulate and achieve the realistic feel of a fretted electronic guitar controller, which includes strings as a triggering mechanism, an abrasion resistant fret such as frets **75** has been developed. Without a fret a buzz-free string would require tighter tolerances and increase the cost. To that end, frets **75** are formed of a UHMW (ultra-high molecular weight-polyethylene), polypropylene, or metal as a layer. This component acts as a true stop for the string and reduces the buzz.

There are distinguishable footprints from a strummed string versed a picked string, a bent string, palm mutes or neck mutes. The characteristic distinctions will be characterized and stored in firmware. The Syntar, electronic instrument **60** will output both MIDI/USB. By using a traditional tuned string mechanism along with the sensitivity of RockingBridge sensors, the release of the string delivers the correct pitch. The RockingBridge sensor can be used to tune the Syntar’s strings. The RockingBridge sensor simulates the string oscillation so well that there is a ¼ output for plugging into an amplifier.

When strings **66** are depressed enough to touch a fret on the neck to determine pitch. A note is not sounded until the

string is released. The fretboard responds to hammer-on triggering (note is sounded when fretboard is struck). The hammer-on trigger is “automatically” differentiated from a “string-release” trigger by the analysis of various characteristic parameters of each. The intended expression of the string is activated when the string is released. The RockingBridge determines the volume of the strum. If there is a rapid quick release the string is considered to be either picked or strummed. If after a string is picked or strummed a varied signal is sent from the Virtual Fret Sensors then the note is considered to be bent. The amount of bend is determined by the degree of change in resistance value that the FSR/LinearPot fretboard outputs, and increased conductance from the RockingBridge sensor. The Up/Down—Right/Left—Enter—control keys are FSR keys and are used to navigate through any application used. The instrument outputs MIDI and USB and is designed for open platform.

An alternate configuration for electronic guitar **60** is illustrated in FIGS. **29-48** that illustrate several alternative continuous string simulators that include the fret section and the strummer section.

Referring now to FIGS. **29-33**, guitar neck **80** is designed to enable travel of this string simulator. It also incorporates note bending response as well as hammer-on. Each string simulator such as string simulators **81** and **82** is formed by string membrane **83** overlaying FSR sensors **86A** and **86B** on substrate **87**. Pressing straight down on the membranes of multiple string simulators as in a bar chord, both the sensors on both sides of the string’s linear pot are activated. As the note is bent, the embossed or otherwise formed, membrane **83** collapses and pinches the FSR circuit or circuits causing force on the force sensing resistor sensors positioned on one or both sides of a string simulator’s linear pot which is used for pitch detection. The amount of force exerted on the sensor can be interpreted as the amount of note bend. While bending a note, if the finger should reach to the adjacent string simulator’s force sensor, extreme note bend is sounded in response.

In string simulator **90** of FIGS. **34-48**, multiple string simulator vanes such as vane **91** are embedded into flexible form **92**. Vanes such as vane **91** are formed of any suitable hard, flexible material such as urethane or other polymers. Flexible form **92** may be made of any suitable material such as silicon, rubber or other polymer. Flexible form **92** includes elements such as pull-through tie-downs **94** that connect form **92** and vanes **91** to base **96** and support web **97** that suspends the vanes **91** above the FSR membrane **98**.

Vanes such as vane **91** may includes a continuous “fret-like string” to be fed through openings such as fret openings **93** with an opening at the bridge end of the neck/body. The “fret-like string” is kept in place by braces that are designed to maintain the neck integrity, and keep the neck from splaying open when the string is pulled when bending a note. A printed circuit board, base **96**, includes silicone rubber covered FSR **98** secured under the “string system” and detects string pulls, pushes, and strummed string. Vanes **91** may also include slots or openings **95** to provide a more accurate simulation of conventional guitar strings and provide discrete locations **95X** for flex when force is applied to the strings.

Electronic bow **100** of FIGS. **44-46** is used for applying force to a string or string simulator. Electronic bow **100** includes tubular element **101** with a tensioning mount, such as tensioning mount **102**, at one or both ends for adjusting tension of linear sensor **104**. Linear sensor **104** has flexible layer **104A** adhered to contact surface **105** to improve friction and add “grab” when pulled over a string or string

simulator. Linear sensor **104** may be formed of any suitable rubber, plastic or polymer material. Tension adjusting handle **106** and or tubular element **101** enclose operational electronics **107**. Electronic bow **100** may be wired or wireless. Linear sensor **104** is composed of fixed resistor layer **108** deposited on PET layer **104X**, and wiper layer **109** between resistor layer **108** and flexible layer **104A**. Linear sensor **104** is secured to tension mounts **102** using any suitable adhesive or any suitable fastener such as fastener **110**.

Electronic wind instrument **120** of FIGS. **52** through **58** is a synthesized electronic wind instrument. Instrument body **118** has a wind instrument form-factor with fingering similar to a flute, clarinet or saxophone. Each key such as FSR keys **118A** and **118B** has a “Trampoline” style button or FSR key, as discussed above, made of embossed plastic raised surface to give tactical feedback and to help the player locate the button’s position and state of activation. The essence of the Trampoline sensor or FSR key is to increase the travel of the switch/sensor and to minimize the hard feel at the end of travel of a rigid backed substrate. The trampoline system achieves this by cutting out an opening in the rigid substrate that outlines the shape of the switch/sensor. The keys such as FSR keys **118A** and **118B** are FSR sensors for multiple uses such as expressive playing without blowing.

Referring now to FIGS. **56** and **57**, mouthpiece **121** is an example of an electronic mouthpiece incorporating FSR sensors, lip sensor **122** and breath sensor **123**. Any suitable lip sensor may be used with mouthpiece **121**, such as purse sensor **124**. In breath sensor **123** the user’s breath deforms diaphragm **125** in chamber **126** with bleed off valve **127**. The diaphragm **125** is pre-loaded and engages FSR sensor element **128** such that changing pressure in chamber **126** results in a corresponding change in conductivity of FSR sensor **128**. Changing conductivity of FSR sensor **128** enables microprocessor **129** to determine the volume of the note based on the force of the user’s breath. This can also be made using a ThruMode FSR sensor, where the FSR is printed over the electrodes on the two facing substrates as shown in FIGS. **65-70**.

Multiple mouthpiece designs incorporate position and force sensing to enable microprocessor **129** to determine where and how intensely the user is applying lip force against the lip sensor such as purse sensor **124**. This information can be interpreted to give emotion to the instrument’s voice. Mouthpiece controllers are either brass-style (pursing) lip sensors such as first lip sensor **124** or alternate lip sensor **130** or a woodwind-style mouthpiece **132** as illustrated in FIGS. **58** through **60** with lip sensor **133**. The brass-style mouthpiece incorporates two FSR sensors **130A** and **130B** to determine the position and force of the upper and lower lip respectively. Similarly, mouthpiece **132** incorporates upper and lower lip sensors **133A** and **133B** respectively.

Referring now to brass-style lip sensor **130** of FIGS. **61-64**, sensor **130** is designed to deliver as much expression as possible while maintaining the player’s expected or anticipated form factor of that instrument. FSR element or elements are incorporated in layers **134** and **136** which are molded or inmolded with body **135** and connect to a microprocessor or other controller with signal conductors in tail **137**. FSR sensor layers **134** and **136** are shaped to conform to lip contact surface **135A** of mouthpiece body **135**. In the case of the sensor **130**, an oval shape may be incorporated to more accurately mirror the shape of the lips and to achieve a greater surface area of contact for the lips to enable greater XYZ response. For electronic instruments such as trombones or larger brass instruments, brass-style lip

sensor **130** may have a large body **135** formed with a large oval shape. The area of contact is more than that of an acoustic instrument, but since the instrument is not designed to respond to the players lip “buzz” this alternative design enables controls beyond the expectations of an acoustic instrument.

In the “traditional mode”, the instrument reads from the mouthpiece sensor and waits for the user to breathe into the mouthpiece to trigger a sound. Once breathe is detected the volume of the note is determined based on the force of the breathe. The instrument can also be played in NoBreathe mode for those who want to sing and play at the same time. All these inputs are combined to give the expression of the note passed to the speaker.

Fundamental frequencies can be created by blowing harder. Breath sensor **123** measures breath pressure applied by a user. The lip position simulates adjusting the resonate chamber in the mouth. Being able to measure the opening and closing of the mouth against the lip sensor simulates the larger and smaller chamber. These two features in conjunction with software are enough to simulate the physics of a brass or woodwind instrument’s mouthpiece.

Trampoline Keys. The essence of the Trampoline sensor is to increase the travel of the switch/sensor and to minimize the hard feel at the end of travel from a rigid backed substrate. The trampoline system achieves this by cutting out an opening in the rigid substrate that outlines the shape of the switch/sensor. The Up/down—right/left—Enter function keys are FSR keys and are used to change any function such as how keys respond to finger force, assignment to the linear pot, as well as changing the voice of the instrument.

The wind sensor determines how much breathe is being applied to determine the volume of note to be played. The pursing lip sensor can determine the position and force of each the upper and lower lips upon the sensor. The force applied to the key buttons can be used in the NoBreathe mode for expression of any programmable expression assigned to it. User input keys are used to change the instrument voice and other functions to be determined. All instruments communicate with each other in conductor or player mode so a person as a conductor has encoded data they send to other players to follow along with electronic radio, TV or other.

Referring now to FIGS. **65-70**, ThruMode sensor **140** is suitable for lip sensors as discussed above and is formed of first sensor **141** and second sensor circuit **142**. First and second sensor circuit elements **141** and **142** are oriented in apposition as shown in FIGS. **69** and **70** for use. Highly conductive electrodes **143** of such inks as silver or carbon are deposited on first substrate **144** and second substrate **145**. Conductors **143** are overprinted with FSR elements **146**. The silver conductive inks demonstrate more “standoff” and dynamic range than the carbon conductor due to the topography caused by the silver flakes and lack of topography of the micro carbon particles. Dielectric layer or layers **147** are printed on one or both of the first and or second sensor circuit elements **141** and **142** respectively.

ShuntMode FSR lip sensor **150** consists of substrate **152** printed with highly conductive interdigitating finger trace patterns such as trace patterns **153** and **154** made of such conductive inks as silver or carbon, which is oriented in apposition to a second substrate, substrate **156** with FSR elements **158** printed and cured upon it.

Electronic trombone **160** of FIGS. **74-77** uses any suitable lip sensor **161** such as brass-style lip sensors **124** and **130** to sense exerted pressure and position of the upper and lower lips. It also used the FSR pressure chamber and release valve

13

for amplitude. Linear Pot 162 is used to determine the position of the “slide for pitch identification. Alternatively, a proximity or distance sensor such as IR can be used to measure the position of the slide.

Referring now to FIGS. 78 through 83, alternate electronic guitar 170 includes extruded elastomer elements or vanes such as vanes 172 in place of conventional guitar strings. Vanes 172 extend from strum area 170A all along neck 170N. The shape of vanes 172 is a variation of the segmented inverted “T” formed vanes 91 discussed above. Vanes 172 may be formed of separate elements 172A and 172B secured together by elastomer 173. Alternatively, vane 174 may be formed of two different co-molded materials flexible portion 175 and structural portion 176.

FIGS. 84 through 87 illustrate an alternate fretboard 180 consisting of FSR membrane 182 over a flexible set of ribs 183 representing the instrument strings.

While the preferred embodiments of the devices and methods have been described in reference to the environment in which they were developed, they are merely illustrative of the principles of the inventions. The elements of the various embodiments may be incorporated into each of the other species to obtain the benefits of those elements in combination with such other species, and the various beneficial features may be employed in embodiments alone or in combination with each other. Other embodiments and configurations may be devised without departing from the spirit of the inventions and the scope of the appended claims.

I claim:

1. A fretboard for an electronic musical instrument having a plurality of strings stretched over an instrument neck comprising:

- a plurality of resistor pads arranged along the instrument neck between the strings and the instrument neck, wherein the plurality of resistor pads are operatively connected to a controller;

14

a plurality of frets wherein each fret is oriented adjacent to at least one of the plurality of resistor pads;

a plurality of FSR sensors interposed between the plurality of resistor pads and operatively connected to the controller; and

wherein, the controller is operable to produce output signals corresponding to excitement of one or more of the plurality of strings and pressure and location of pressure applied to one or more of the plurality of strings through one or more of the resistor pads along the instrument neck and/or pressure and location of pressure applied to one or more of the plurality of strings through one or more of the FSR sensors along the instrument neck.

2. The fretboard of claim 1 wherein the plurality of frets are formed of ultra-high molecular weight polyethylene.

3. The fretboard of claim 1 wherein the plurality of frets are formed of polypropylene.

4. The fretboard of claim 1 wherein the plurality of frets are formed in a membrane layer of metal over the fretboard.

5. The fretboard of claim 3 wherein the plurality of resistor pads are a plurality of linear pots.

6. The fretboard of claim 5 further comprising:

a plurality of FSR sensors interposed between the plurality of linear pots and operatively connected to the controller.

7. The fretboard of claim 5 wherein the plurality of frets are formed of ultra-high molecular weight polyethylene.

8. The fretboard of claim 5 wherein the plurality of frets are formed of polypropylene.

9. The fretboard of claim 5 wherein the plurality of frets are formed in a membrane layer of metal over the fretboard.

\* \* \* \* \*